

# 2007 Mazda MX-5 Miata Sport

2007 RESTRAINTS Air Bag System - MX-5 Miata

## 2007 RESTRAINTS

### Air Bag System - MX-5 Miata

#### LOCATION INDEX

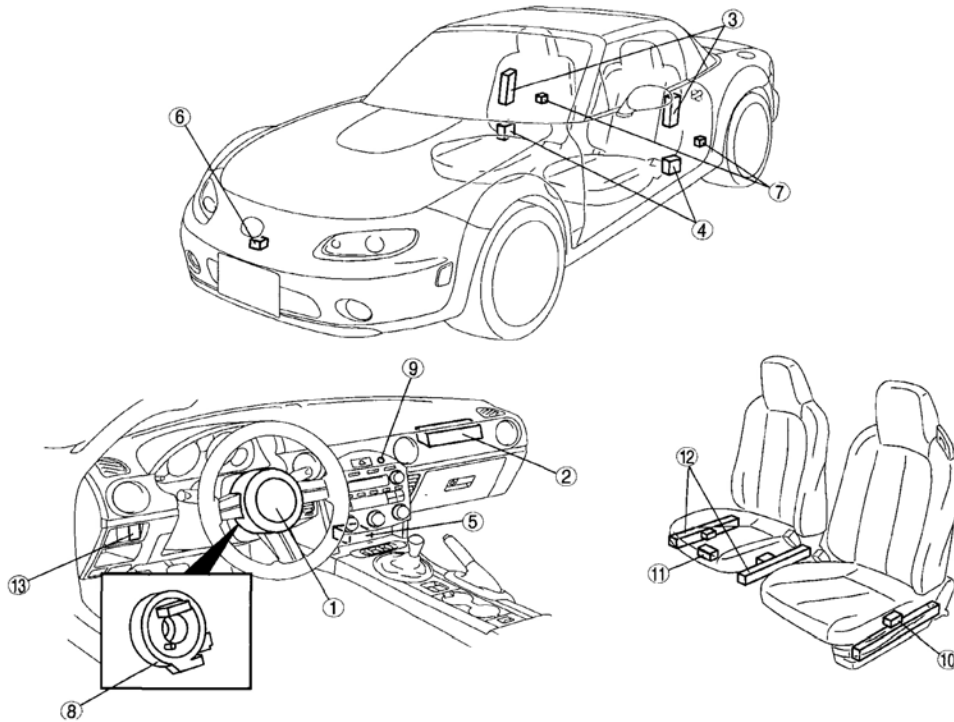

E5U810ZW5101

1	Driver-side air bag module
2	Passenger-side air bag module
3	Side air bag module
4	Pre-tensioner seat belt
5	SAS control module
6	Crash zone sensor
7	Side air bag sensor
8	Clock spring
9	Passenger air bag deactivation (PAD) indicator
10	Seat track position sensor
11	Seat weight sensor control module
12	Seat weight sensor
13	Passenger air bag deactivation (PAD) switch

**Fig. 1: Identifying Location Of Airbag Components**  
Courtesy of MAZDA MOTORS CORP.

#### AIR BAG SYSTEM SERVICE WARNINGS

## AIR BAG MODULE INSPECTION

- Inspecting an air bag module using a tester can operate (deploy) the air bag module, which may cause serious injury. Do not use a tester to inspect an air bag module. Always use the on-board diagnostic function to diagnose the air bag module for malfunctions.

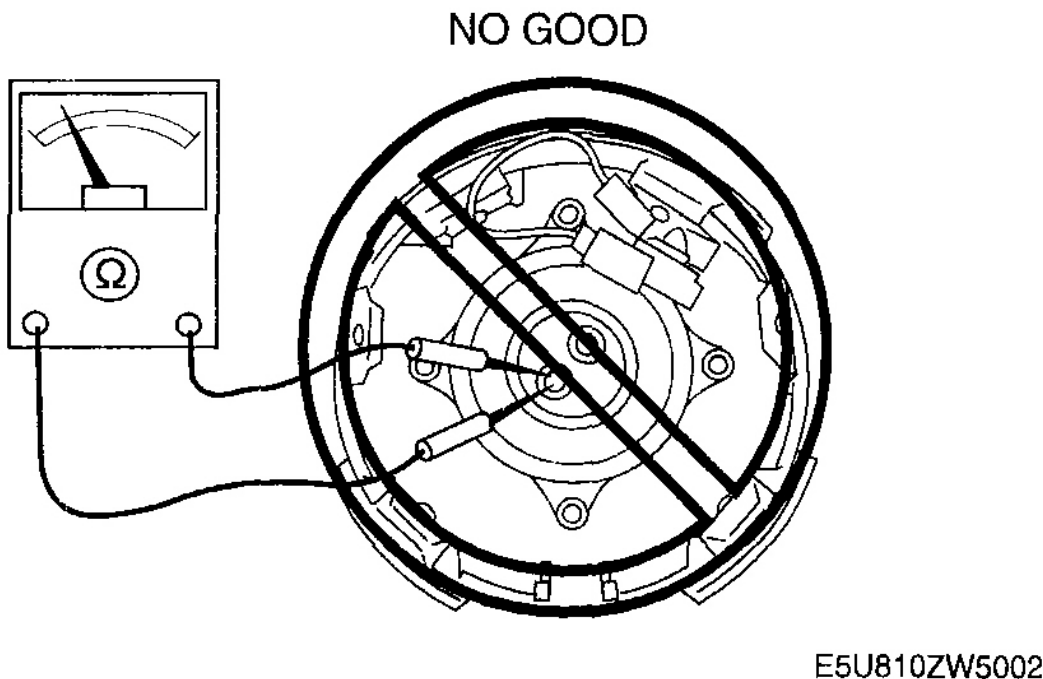

**Fig. 2: Inspecting Air Bag Module Caution**  
Courtesy of MAZDA MOTORS CORP.

## AIR BAG MODULE HANDLING

- Before removing the air bag module or disconnecting the air bag module connector, always turn the ignition switch to the LOCK position, disconnect the negative battery cable, and then wait for 1 min or more to allow the backup power supply of the SAS control module to deplete its stored power.
- Handling a live (undeployed) air bag module that is pointed toward your body could result in serious injury if the air bag module were to accidentally operate (deploy). When carrying a live (undeployed) air bag module, point the deployment surface away from your body to lessen the chance of injury in case it operates (deploys).

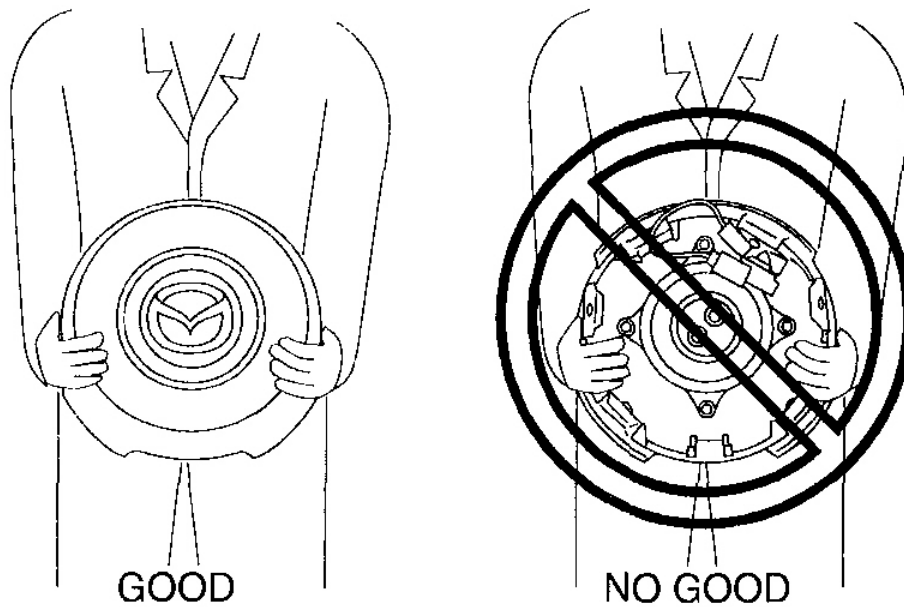

E5U810ZW5003

**Fig. 3: Air Bag Module Handling (1 Of 2)**  
Courtesy of MAZDA MOTORS CORP.

- A live (undeployed) air bag module placed with its deployment surface to ground is dangerous. If the air bag module were to accidentally operate (deploy), it could cause serious injury. Always place a live (undeployed) air bag module with its deployment surface up.

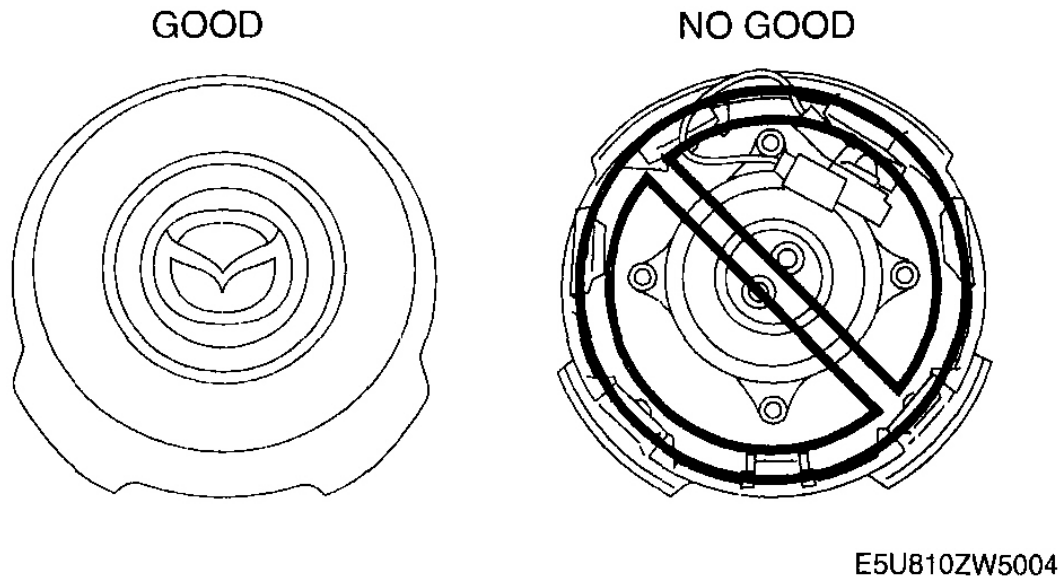

**Fig. 4: Air Bag Module Handling (2 Of 2)**  
Courtesy of MAZDA MOTORS CORP.

#### **SIDE AIR BAG MODULE HANDLING**

- When a side air bag module operates (deploys) due to a collision, the interior of the seat back (pad, frame, trim) may become damaged. If a side air bag does not operate (deploy) normally from a seat back that has been reused, a serious accident may result. After a side air bag has operated (deployed), always replace both the side air bag module and the seat back (pad, frame, trim) with new parts. After servicing, verify that the seat operates normally and that the wiring harness is not caught.

#### **SEAT WEIGHT SENSOR HANDLING**

- The passenger-side seat and the seat weight sensor may become deformed or otherwise damaged due to operation (deployment) of the front or side air bag in an accident. This may cause the passenger sensing function to operate improperly and result in a serious accident. Always replace the passenger seat and seat weight sensor with new ones after the front or side air bags have operated (deployed). After servicing, verify that the seat operates normally and that the wiring harness is not caught. If the collision is not hard enough to cause the front or side air bags to operate (deploy), inspect the seat weight sensor and replace it if there is any malfunction.

#### **SAS CONTROL MODULE HANDLING**

- Removing the SAS control module or disconnecting the SAS control module connector with the ignition switch at the ON position can activate the sensor in the SAS control module and operate

**(deploy) the air bags and pre-tensioner seat belts, which may cause serious injury. Before removing the SAS control module or disconnecting the SAS control module connector, always turn the ignition switch to the LOCK position, disconnect the negative battery cable, and then wait for 1 min or more to allow the backup power supply of the SAS control module to deplete its stored power.**

- **Connecting the SAS control module connector with the SAS control module not securely fixed to the vehicle is dangerous. The sensor in the SAS control module could send an electrical signal to the air bag modules and pre-tensioner seat belts. This will operate (deploy) the air bags and pre-tensioner seat belts, which may result in serious injury. Therefore, before connecting the connector, securely fix the SAS control module to the vehicle.**
- **Because a sensor is built into the SAS control module, once the air bags and pre-tensioner seat belts have operated (deployed) due to a collision or other causes, the SAS control module must be replaced with a new one even if the used one does not have any visible external damage or deformation. The used SAS control module may have been damaged internally, which may cause improper operation. If the SAS control module is reused, the air bags and pre-tensioner seat belts may not operate (deploy) normally, which could result in a serious accident. Always replace the SAS control module with a new one. The SAS control module cannot be bench-checked or self-checked.**

### **CRASH ZONE SENSOR HANDLING**

- **Removing the crash zone sensor or disconnecting the crash zone sensor connector with the ignition switch at the ON position can activate the crash zone sensor and operate (deploy) the air bags and pre-tensioner seat belts, which may cause serious injury. Before removing the crash zone sensor or disconnecting the crash zone sensor connector, always turn the ignition switch to the LOCK position, disconnect the negative battery cable, and then wait for 1 min or more to allow the backup power supply of the SAS control module to deplete its stored power.**
- **If the crash zone sensor is subjected to shock or the sensor is disassembled, the air bags and pre-tensioner seat belts may accidentally operate (deploy) and cause injury, or the system may fail to operate normally and cause a serious accident. Do not subject the crash zone sensor to shock or disassemble the sensor.**
- **Because a sensor is built into the crash zone sensor, once the air bags and pre-tensioner seat belts have operated (deployed) due to a collision or other causes, the crash zone sensor must be replaced with a new one even if the used one does not have any visible external damage or deformation. If the crash zone sensor is reused, the air bags and pre-tensioner seat belts may not operate (deploy) normally, which could result in a serious accident. Always replace the crash zone sensor with a new one. The crash zone sensor cannot be bench-checked or self-checked.**

### **SIDE AIR BAG SENSOR HANDLING**

- **Removing the side air bag sensor or disconnecting the side air bag sensor connector with the ignition switch at the ON position can activate the side air bag sensor and operate (deploy) the side air bag, which may cause serious injury. Before removing the side air bag sensor or disconnecting the side air bag sensor connector, always turn the ignition switch to the LOCK position, disconnect the negative battery cable, and then wait for 1 min or more to allow the backup power supply of the SAS control module to deplete its stored power.**

- If the side air bag sensor is subjected to shock or the sensor is disassembled, the side air bag may accidentally operate (deploy) and cause injury, or the system may fail to operate normally and cause a serious accident. Do not subject the side air bag sensor to shock or disassemble the sensor.
- Because a sensor is built into the side air bag sensor, once the air bag has operated (deployed) due to a collision or other causes, the side air bag sensor must be replaced with a new one even if the used one does not have any visible external damage or deformation. If the side air bag sensor is reused, the side air bag may not operate (deploy) normally, which could result in a serious accident. Always replace the side air bag sensor with a new one. The side air bag sensor cannot be bench-checked or self-checked.

### PRE-TENSIONER SEAT BELT INSPECTION

- Inspecting a pre-tensioner seat belt using a tester can operate (deploy) the pre-tensioner seat belt, which may cause serious injury. Do not use a tester to inspect a pre-tensioner seat belt. Always use the on-board diagnostic function to diagnose the pre-tensioner seat belt for malfunctions.

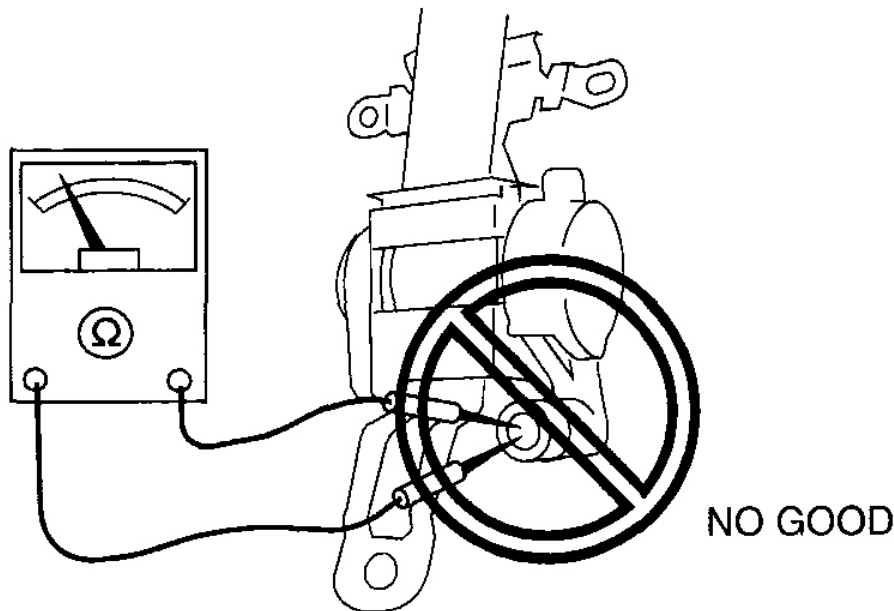

E5U810ZW5005

**Fig. 5: Inspecting Pre-Tensioner Seat Belt Using Tester Caution**  
Courtesy of MAZDA MOTORS CORP.

## AIR BAG SYSTEM SERVICE CAUTIONS

### AIR BAG SYSTEM COMPONENT DISASSEMBLY

- **Disassembling the air bag system components could cause it to not operate (deploy) normally. Never disassemble any air bag system components.**

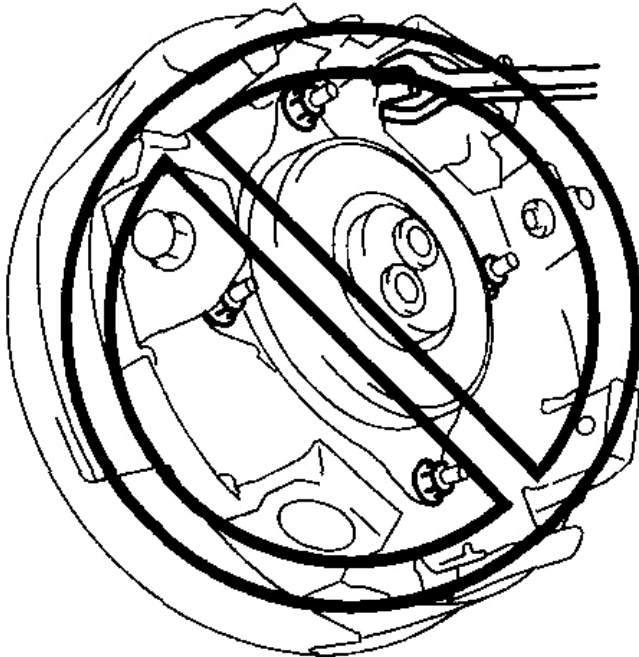

**NO GOOD**

E5U810ZW5006

**Fig. 6: Air Bag System Service Cautions**  
Courtesy of MAZDA MOTORS CORP.

#### **AIR BAG MODULE, PRE-TENSIONER SEAT BELT HANDLING**

- **Oil, grease, or water on the air bag modules may cause the air bags and pre-tensioner seat belts to fail to operate (deploy) in an accident. Never allow oil, grease, or water to get on the air bag modules or pre-tensioner seat belts.**
- **Inserting a screwdriver or similar object into the connector of an air bag module or a pre-tensioner seat belt may damage the connector and cause the air bag module or the pre-tensioner seat belt to operate (deploy) improperly, which may cause serious injury. Never insert any foreign objects into the air bag module or seat belt connectors.**

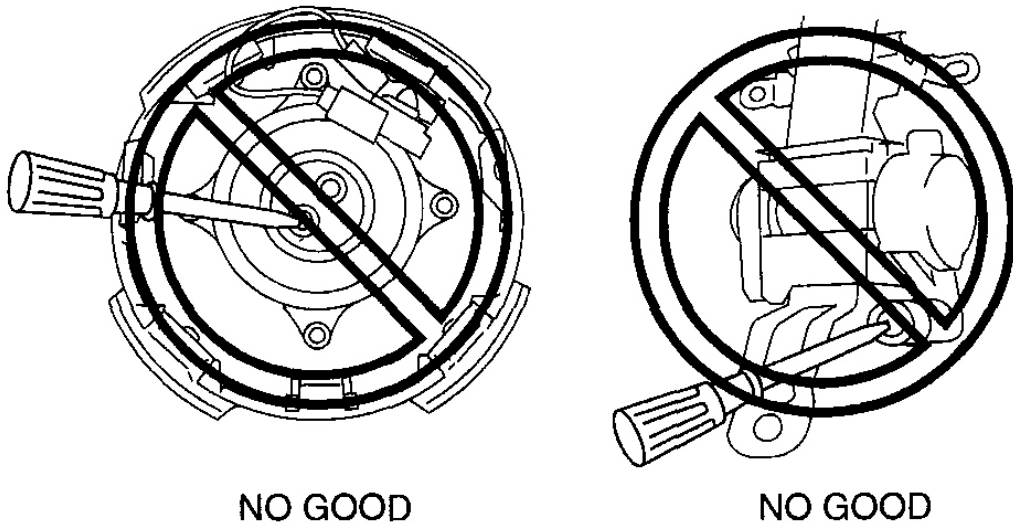

E5U810ZW5007

**Fig. 7: Air Bag Module & Pre-Tensioner Seat Belt Handling Caution**  
Courtesy of MAZDA MOTORS CORP.

#### SEAT WEIGHT SENSOR HANDLING

- The seat weight sensor has a built-in strain gauge which may operate improperly if the sensor is dropped by itself or when installed to the seat. If it is dropped, replace the seat weight sensor with a new one.
- Oil, grease, or water on the seat weight sensor may cause the system to operate (deploy) improperly. Never allow oil, grease, or water to get on the seat weight sensor.
- Foreign material in the seat weight sensor components may cause the system to operate (deploy) improperly. Always make sure that no foreign material can get into the seat weight sensor.
- Disassembling the seat weight sensor, or tightening any of the nuts and bolts installed to the sensor body may cause it to operate (deploy) improperly. Never disassemble the seat weight sensor or tighten any of the nuts or bolts installed to the body of the sensor.

#### AIR BAG MODULE, PRE-TENSIONER SEAT BELT REUSE

- Even if an air bag module or a pre-tensioner seat belt does not operate (deploy) in a collision and does not have any external signs of damage, it may have been damaged internally, which may cause improper operation. Before reusing a live (undeployed) air bag module and the pre-tensioner seat belts, always use the on-board diagnostic to diagnose the air bag module and the pre-tensioner seat belts to verify that they have no malfunction.

#### AIR BAG WIRING HARNESS REPAIR



- **Incorrectly repairing an air bag wiring harness can accidentally operate (deploy) the air bag module and pre-tensioner seat belts. If a problem is found in the air bag wiring harness, always replace the wiring harness with a new one.**



CHU0810W606

**Fig. 8: Identifying Air Bag Wiring Harness Repair Caution**  
Courtesy of MAZDA MOTORS CORP.

## **PASSENGER AIR BAG DEACTIVATION (PAD) INDICATOR REMOVAL/INSTALLATION**

1. Remove the battery cover.
2. Disconnect the negative battery cable. (See **BATTERY REMOVAL/INSTALLATION [LF]** .)
3. Remove the following parts:
  1. Side wall (See **SIDE WALL REMOVAL/INSTALLATION** .)
  2. Center panel unit (See **CENTER PANEL UNIT REMOVAL/INSTALLATION** .)
  3. Remove the glove compartment. (See **GLOVE COMPARTMENT REMOVAL/INSTALLATION** .)
  4. Decoration panel (See **DECORATION PANEL REMOVAL/INSTALLATION** .)
4. Remove in the order indicated in **Fig. 9** .

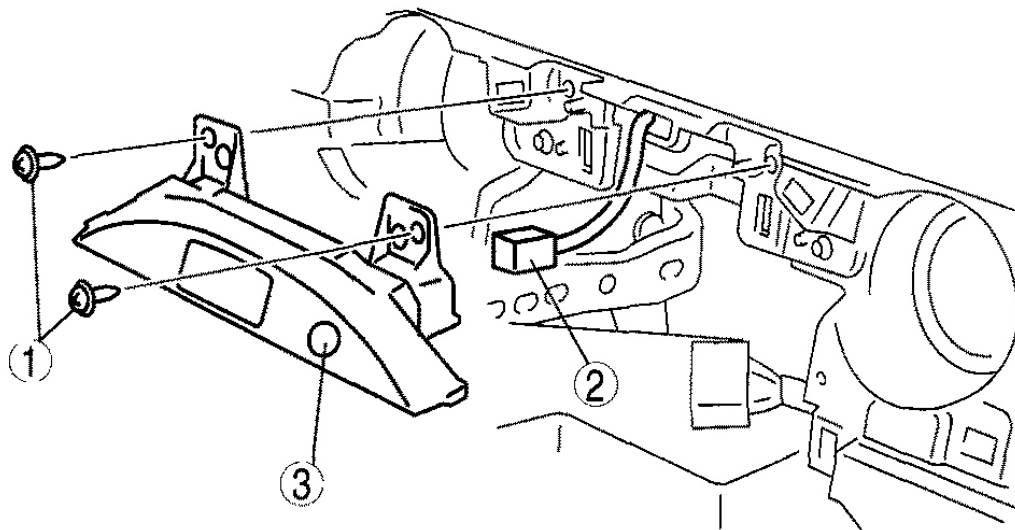

E5U810ZW5022

1	Screw
2	Connector
3	Passenger air bag deactivation (PAD) indicator

**Fig. 9: Removing/Installing Passenger Air Bag Deactivation (PAD) Indicator**  
 Courtesy of MAZDA MOTORS CORP.

5. Install in the reverse order of removal.

## DRIVER-SIDE AIR BAG MODULE REMOVAL/INSTALLATION

### WARNING:

- Handling the air bag module improperly can accidentally deploy the air bag module, which may seriously injure you. Read the air bag system service warnings and cautions before handling the air bag module. (See **AIR BAG SYSTEM SERVICE WARNINGS** .) (See **AIR BAG SYSTEM SERVICE CAUTIONS** .)

1. Turn the ignition switch to the LOCK position.
2. Remove the battery cover.
3. Disconnect the negative battery cable and wait for **1 min or more** . (See **BATTERY REMOVAL/INSTALLATION [LF]** .)
4. Remove in the order indicated in **Fig. 10** .

VEHICLE WITH STEERING SWITCH

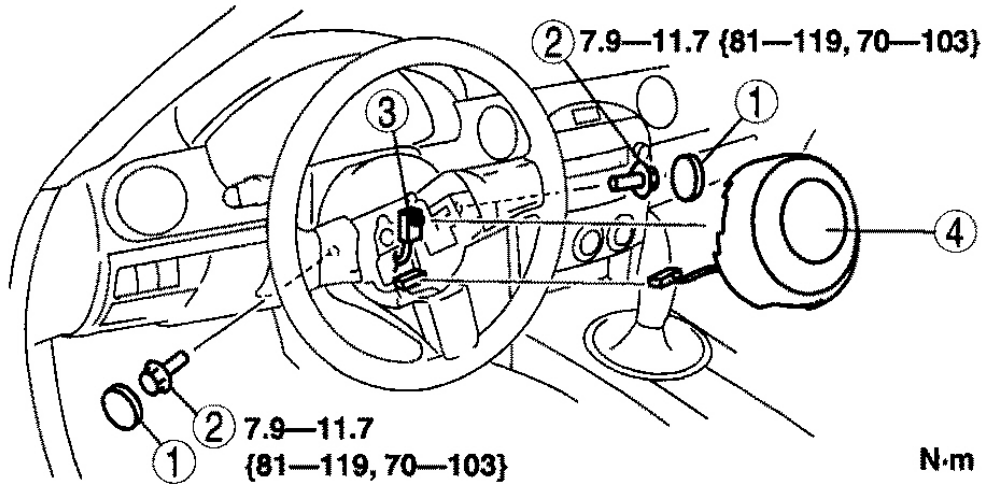

VEHICLE WITHOUT STEERING SWITCH

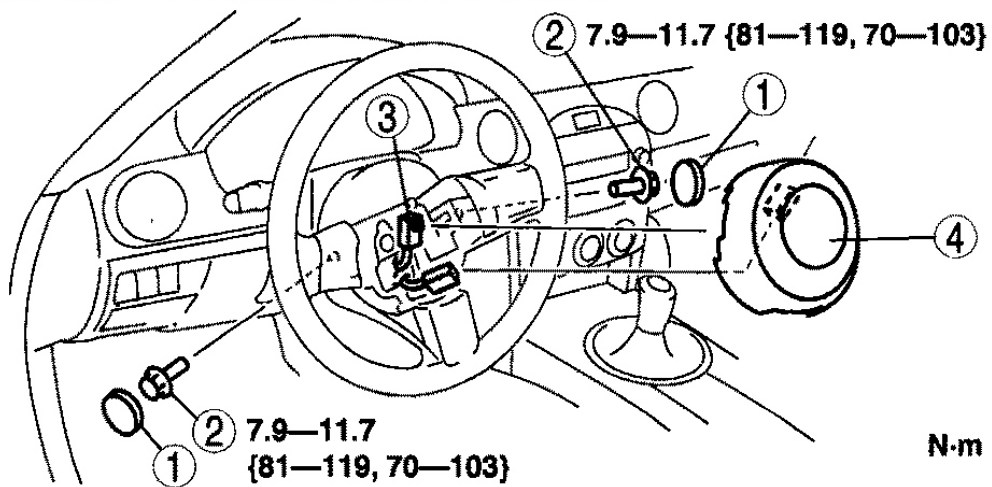

E5U810ZW5108

1	Cover
2	Bolt
3	Connector
4	Driver-side air bag module

**Fig. 10: Removing/Installing Driver-Side Air Bag Module (With Torque Specifications)**  
 Courtesy of MAZDA MOTORS CORP.

5. Install in the reverse order of removal.

6. Turn the ignition switch to the ON position.
7. Verify that the air bag system warning light illuminates for **approx. 6 s** and goes out.
  - If the air bag system warning light does not operate normally, refer to **RESTRAINTS -- ON-BOARD DIAGNOSTIC** system (air bag system) and perform inspection of the system.

#### CONNECTOR REMOVAL NOTE

1. Using a flathead screwdriver, pry out the connector stopper plate.

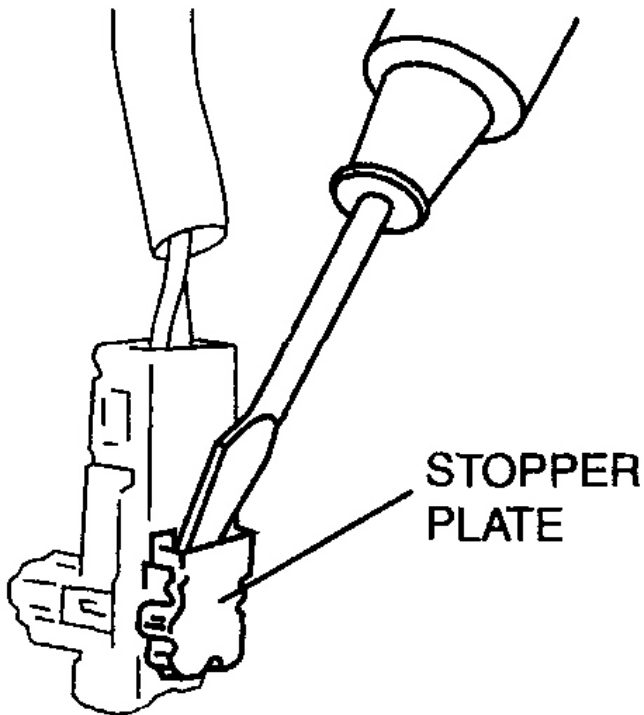

CHU0810W003

**Fig. 11: Prying Out Connector Stopper Plate**  
Courtesy of MAZDA MOTORS CORP.

2. Disconnect the connector.

#### PASSENGER-SIDE AIR BAG MODULE REMOVAL/INSTALLATION

**WARNING:**

- Handling the air bag module improperly can accidentally deploy the air bag module, which may seriously injure you. Read the air bag

## 2007 Mazda MX-5 Miata Sport

2007 RESTRAINTS Air Bag System - MX-5 Miata

**system service warnings and cautions before handling the air bag module. (See AIR BAG SYSTEM SERVICE WARNINGS .) (See AIR BAG SYSTEM SERVICE CAUTIONS .)**

- **If the passenger-side air bag module is installed with debris in the module, it may be scattered when the air bag module operates (deploys), causing injury. Verify that there is no debris in the passenger-side air bag module before installation.**
- **If a damaged passenger-side air bag module is installed, the vehicle may be damaged or the passenger may be injured when the air bag module operates (deploys). Verify that the passenger-side air bag has no damage before installation.**
- **Due to the adoption of 2-step deployment control in the passenger-side air bag module, depending on the impact force, it is possible that inflator No.2 might not deploy. In such cases, before disposing of the air bag module, make sure to follow the inflator deployment procedures and verify complete deployment of inflators No.1 and 2.**

1. Turn the ignition switch to the LOCK position.
2. Remove the battery cover.
3. Disconnect the negative battery cable and wait for **1 min or more** . (See BATTERY REMOVAL/INSTALLATION [LF] .)
4. Remove the glove compartment. (See GLOVE COMPARTMENT REMOVAL/INSTALLATION .)
5. Remove in the order indicated in Fig. 12 .

# 2007 Mazda MX-5 Miata Sport

## 2007 RESTRAINTS Air Bag System - MX-5 Miata

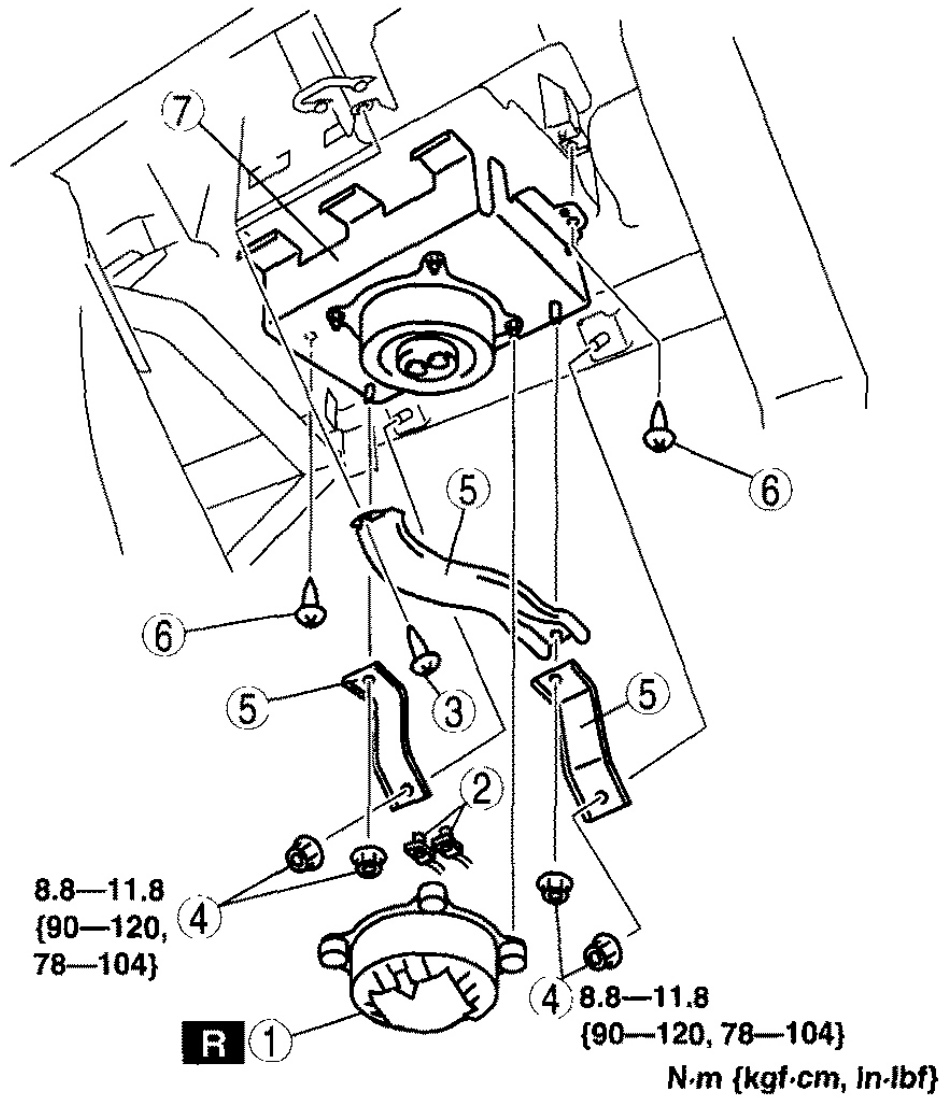

E5U810ZW5109

1	Cap
2	Connector
3	Screw A
4	Nut
5	Bracket
6	Screw B
7	Passenger-side air bag module

**Fig. 12: Removing/Installing Passenger-Side Air Bag Module (With Torque Specifications)**  
 Courtesy of MAZDA MOTORS CORP.

6. Install in the reverse order of removal.
7. Turn the ignition switch to the ON position.
8. Verify that the air bag system warning light illuminates for **approx. 6 s** and goes out.
  - If the air bag system warning light does not operate, refer to **RESTRAINTS -- ON-BOARD DIAGNOSTIC** system (air bag system) and perform inspection of the system.

### PASSENGER-SIDE AIR BAG MODULE REMOVAL NOTE

1. Remove the passenger-side air bag module in the order indicated below.
  1. Disengage the tab locks by sliding the passenger-side air bag module upward.
  2. Slide the passenger-side air bag module rearward.
  3. Remove the passenger-side air bag module by pulling it from the backside and then down.

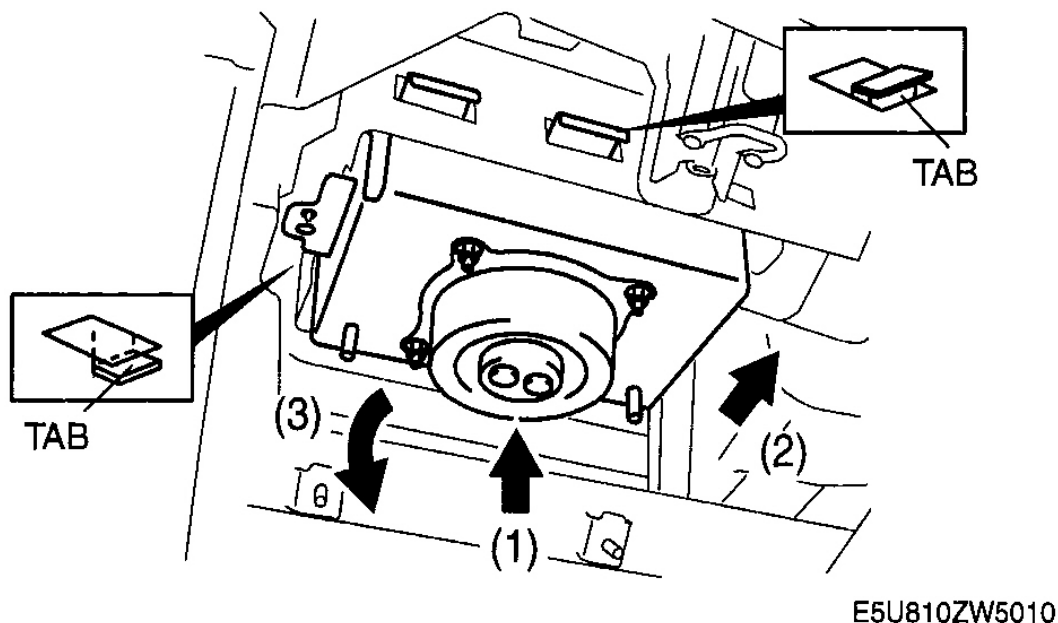

**Fig. 13: Removing Passenger-Side Air Bag Module**  
 Courtesy of MAZDA MOTORS CORP.

### CONNECTOR REMOVAL NOTE

1. Using a flathead screwdriver, pry out the connector stopper plate.

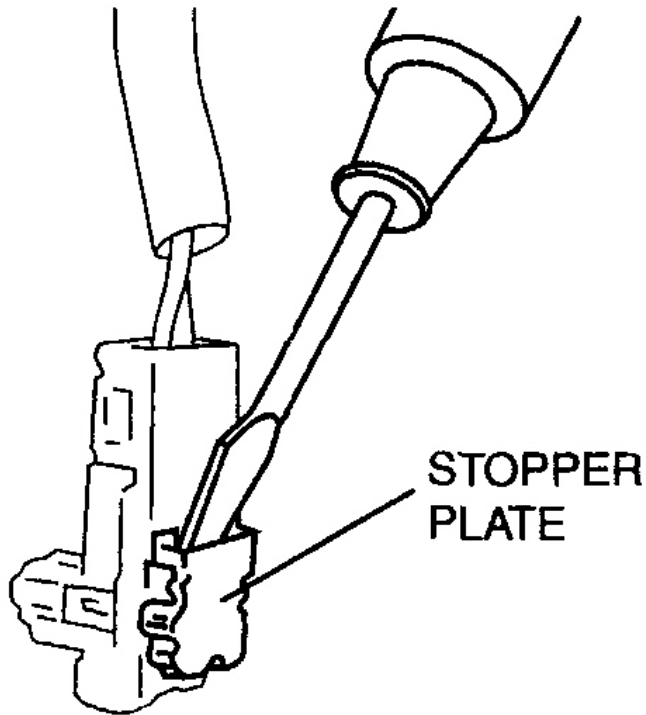

CHU0810W003

**Fig. 14: Prying Out Connector Stopper Plate**  
Courtesy of MAZDA MOTORS CORP.

2. Disconnect the connector.

#### **CAP INSTALLATION NOTE**

1. The cap cannot be reused. Replace the cap with a new one when the cap or the passenger-side air bag module has been removed.

#### **SIDE AIR BAG MODULE REMOVAL/INSTALLATION**

**WARNING:**

- Handling the air bag module improperly can accidentally operate (deploy) the air bag module, which may seriously injure you. Read the air bag system service warnings and cautions before handling the air bag module. (See AIR BAG SYSTEM SERVICE WARNINGS .) (See AIR BAG SYSTEM SERVICE CAUTIONS .)
- If the side air bag module is installed with debris in the seat back,



the foreign material may be scattered when the side air bag module operates (deploys), causing injury. Verify that there is no foreign material in the seat back before installing the side air bag module.

1. Turn the ignition switch to the LOCK position.
2. Remove the battery cover.
3. Disconnect the negative battery cable and wait for **1 min or more** . (See **BATTERY REMOVAL/INSTALLATION [LF]** .)
4. Remove the seat. (See **SEAT REMOVAL/INSTALLATION** .)
5. Detach the tab as shown in **Fig. 15** and remove the connector from the seat connector.

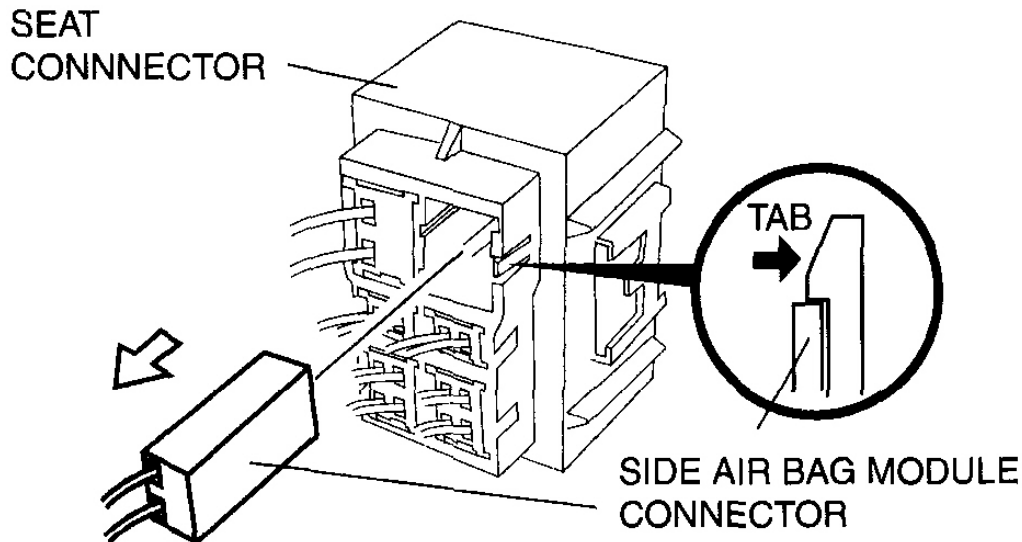

E5U810ZW5029

**Fig. 15: Detaching Tab**  
Courtesy of MAZDA MOTORS CORP.

6. Partially peel back the seat back trim.
7. Partially peel back the seat back pad.
8. Remove in the order indicated in **Fig. 16** .

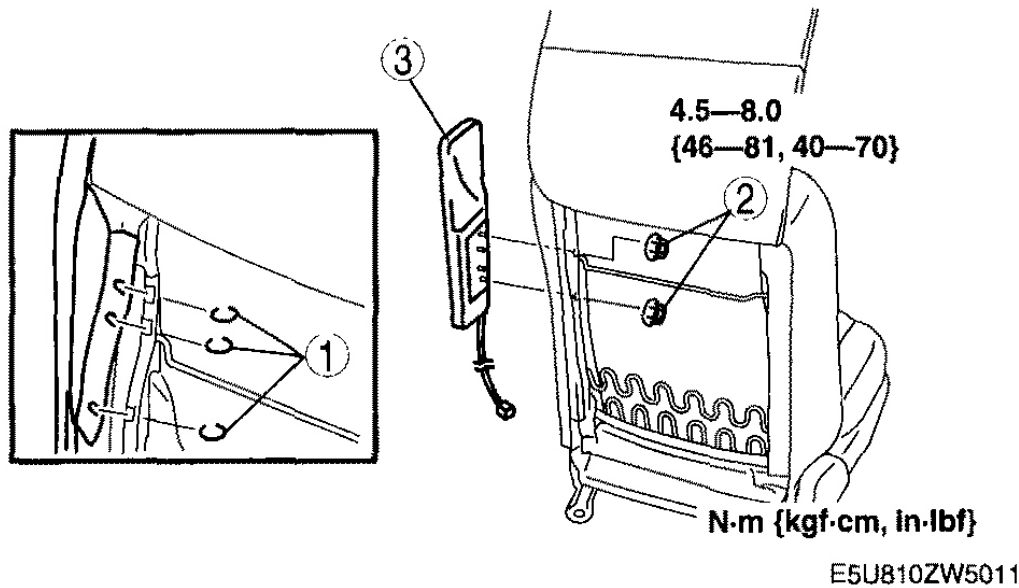

1	Hook
2	Nut
3	Side air bag module

**Fig. 16: Removing Side Air Bag Module (With Torque Specifications)**  
 Courtesy of MAZDA MOTORS CORP.

9. Install in the reverse order of removal.
10. Turn the ignition switch to the ON position.
11. Verify that the air bag system warning light illuminates for **approx. 6 s** and goes out.
  - If the air bag system warning light does not operate normally, refer to **RESTRAINTS -- ON-BOARD DIAGNOSTIC** system (air bag system) and perform inspection of the system.

## CRASH ZONE SENSOR REMOVAL/INSTALLATION

**WARNING:**

- Handling the crash zone sensor improperly can accidentally deploy the air bags and pre-tensioner seat belts, which may seriously injure you. Read the air bag system service warnings and cautions before handling the crash zone sensor. (See **AIR BAG SYSTEM SERVICE WARNINGS** .) (See **AIR BAG SYSTEM SERVICE CAUTIONS** .)

1. Turn the ignition switch to the LOCK position.
2. Remove the battery cover.

3. Disconnect the negative battery cable and wait for **1 min or more** . (See **BATTERY REMOVAL/INSTALLATION [LF]** .)
4. Remove the front bumper. (See **FRONT BUMPER REMOVAL/INSTALLATION** .)
5. Remove the fresh-air duct. (See **INTAKE-AIR SYSTEM REMOVAL/INSTALLATION [LF]** .)
6. Remove in the order indicated in **Fig. 17** .

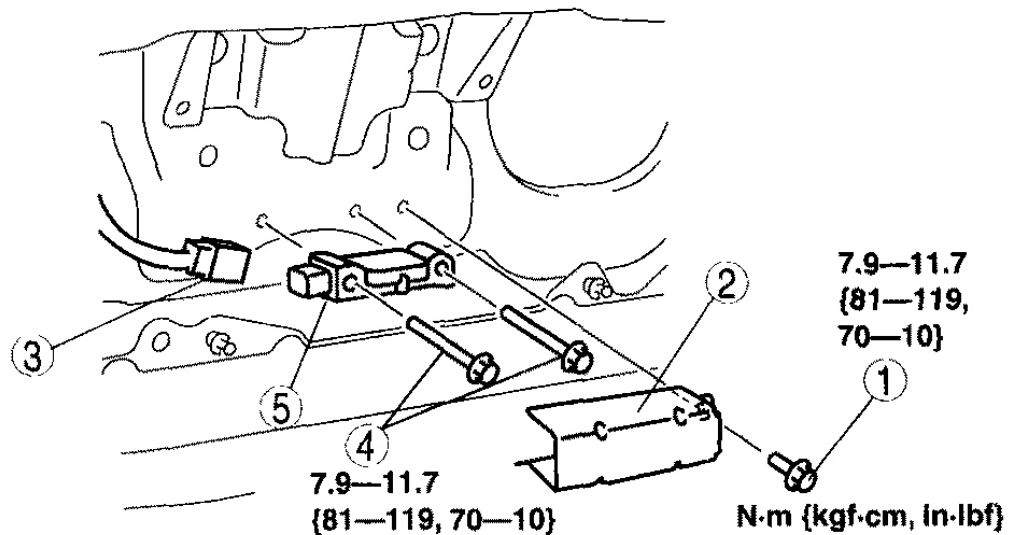

E5U810ZW5112

1	Bolt A
2	Cover
3	Connector
4	Bolt B
5	Crash zone sensor

**Fig. 17: Removing/Installing Crash Zone Sensor (With Torque Specifications)**  
Courtesy of MAZDA MOTORS CORP.

7. Install in the reverse order of removal.
8. Turn the ignition switch to the ON position.
9. Verify that the air bag system warning light illuminates for **approx. 6 s** and goes out.
  - If the air bag system warning light does not operate normally, refer to **RESTRAINTS -- ON-BOARD DIAGNOSTIC** system (air bag system) and perform inspection of the system.

## SAS CONTROL MODULE REMOVAL/INSTALLATION

## 2007 Mazda MX-5 Miata Sport

2007 RESTRAINTS Air Bag System - MX-5 Miata

### WARNING:

- Handling the SAS control module improperly can accidentally deploy the air bag modules and pre-tensioner seat belt, which may seriously injure you. Read the air bag system service warnings and cautions before handling the SAS control module. (See AIR BAG SYSTEM SERVICE WARNINGS .) (See AIR BAG SYSTEM SERVICE CAUTIONS .)

### CAUTION:

- Handling the SAS control module improperly can accidentally deploy the air bag modules and pre-tensioner seat belt, which may seriously injure you. If configuration is not completed before removing the SAS control module, DTC B2477 will be displayed.

1. Perform SAS control module configuration when replacing it. (See SAS CONTROL MODULE CONFIGURATIONS .)
2. Turn the ignition switch to the LOCK position.
3. Remove the battery cover.
4. Disconnect the negative battery cable and wait for **1 min or more** . (See BATTERY REMOVAL/INSTALLATION [LF] .)
5. Remove the following parts:
  1. Console (See CONSOLE REMOVAL/INSTALLATION .)
  2. Side wall (See SIDE WALL REMOVAL/INSTALLATION .)
  3. Console panel (See CONSOLE PANEL REMOVAL/INSTALLATION .)
6. Remove in the order indicated in **Fig. 18** .

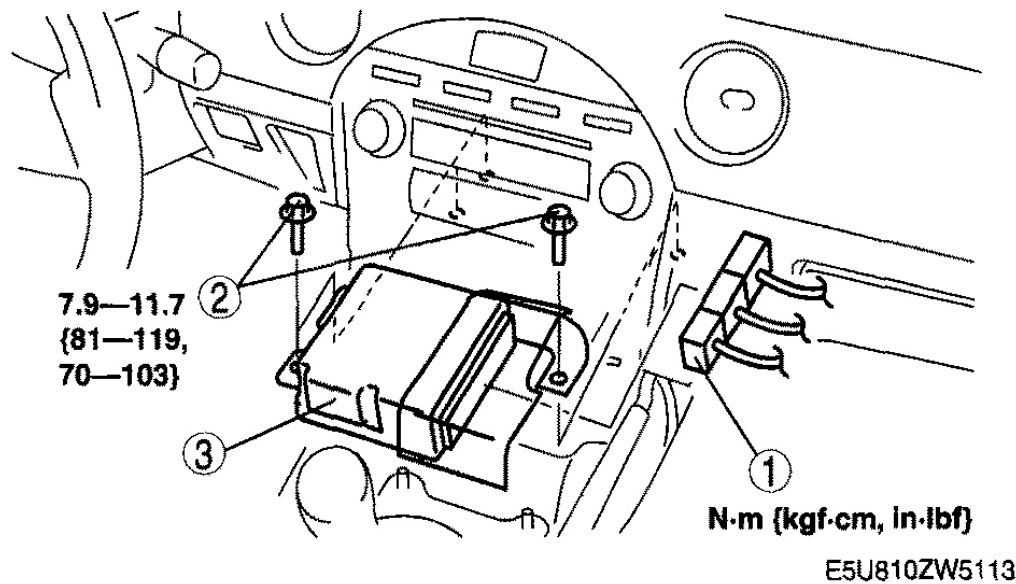

1	Connector
2	Bolt
3	SAS control module

**Fig. 18: Removing/Installing SAS Control Module (With Torque Specifications)**  
 Courtesy of MAZDA MOTORS CORP.

7. Install in the reverse order of removal.
8. Turn the ignition switch to the ON position.
  - If the SAS control module is replaced, turn the ignition switch to the ON position for **20 s or more** after completing the configuration. (See **SAS CONTROL MODULE CONFIGURATION** .)
9. Verify that the air bag system warning light illuminates for **approx. 6 s** and goes out.
  - If the air bag system warning light does not operate normally, refer to **RESTRAINTS -- ON-BOARD DIAGNOSTIC** system (air bag system) and perform inspection of the system.

## SAS CONTROL MODULE CONFIGURATION

1. Connect the M-MDS to the DLC-2 Connector.

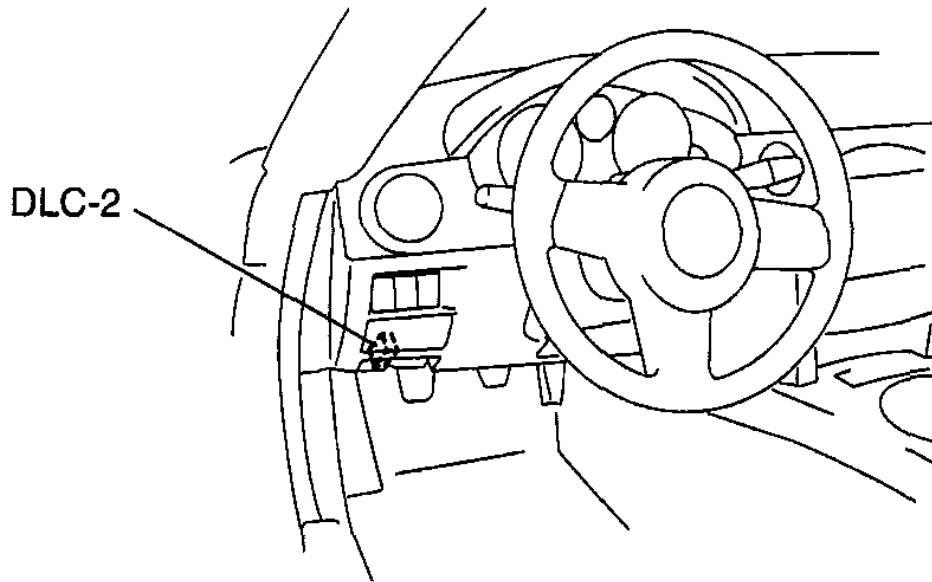

E5U802ZW5100

**Fig. 19: Identifying DLC-2 Location**  
Courtesy of MAZDA MOTORS CORP.

2. After the vehicle is identified, select the following items from the initial screen of the M-MDS.
  - When using the IDS (Laptop PC)
    1. Select "Programming".
  - When using the PDS (Pocket PC)
    1. Select "Programming".
    2. Select "Module Programming".
3. Then Select the "Programmable Module Installation" and "RCM" from the screen menu.
4. Perform the configuration according to the directions on the screen.
5. Retrieve DTCs using the M-MDS, then verify if DTCs are present.
  - If a DTC is present, perform the applicable DTC inspection.

## SEAT TRACK POSITION SENSOR REMOVAL/INSTALLATION

1. Turn the ignition switch to the LOCK position.
2. Remove the battery cover.
3. Disconnect the negative battery cable and wait for **1 min or more** . (See **BATTERY REMOVAL/INSTALLATION [LF]** .)
4. Remove the driver's seat. (See **SEAT REMOVAL/INSTALLATION** .)

5. Detach the tab as shown in **Fig. 20** and remove the connector from the seat connector.

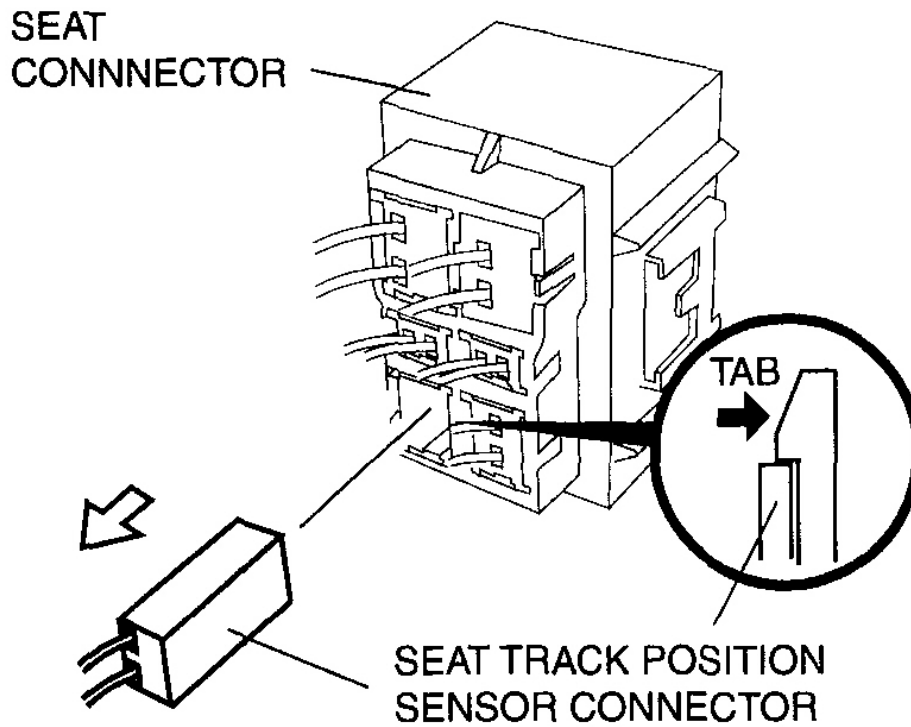

E5U810ZW5035

**Fig. 20: Detaching Seat Connector Tab & Removing Connector From Seat Connector**  
Courtesy of MAZDA MOTORS CORP.

6. Remove in the order indicated in **Fig. 21**.

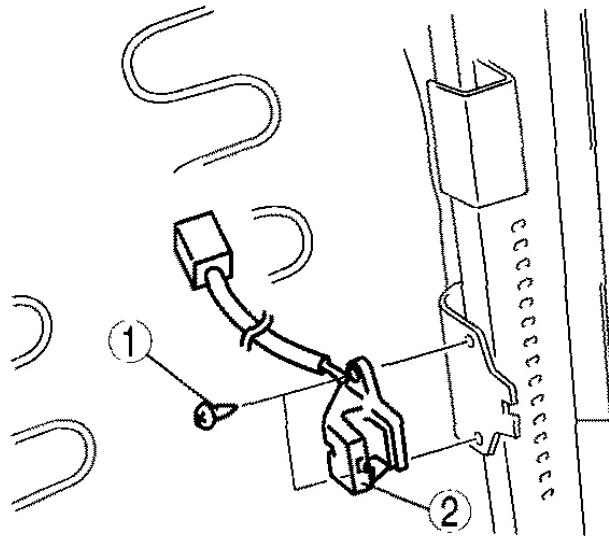

E5U810ZW5014

1	Screw
2	Seat track position sensor

**Fig. 21: Removing Connector From Seat Connector**  
Courtesy of MAZDA MOTORS CORP.

7. Install in the reverse order of removal.

#### SEAT TRACK POSITION SENSOR INSTALLATION NOTE

- Verify that the seat track position sensor is not contacting the metal plate.



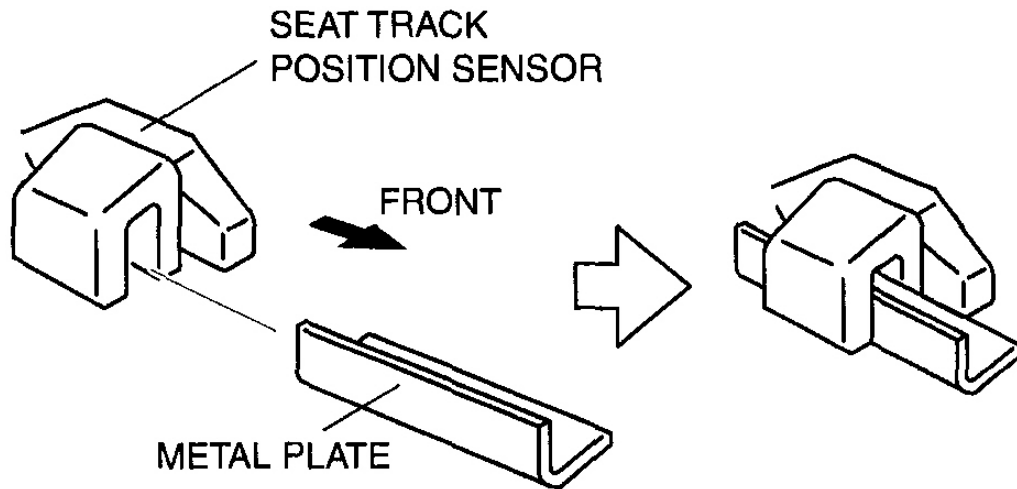

E5U810ZW5033

**Fig. 22: Installing Seat Track Position Sensor**  
Courtesy of MAZDA MOTORS CORP.

## SEAT WEIGHT SENSOR CONTROL MODULE REMOVAL/INSTALLATION

- CAUTION:**
- When the seat weight sensor control module is replaced with a new one, perform the seat weight sensor calibration using the WDS or equivalent. (See SEAT WEIGHT SENSOR CALIBRATION .)

1. Turn the ignition switch to the LOCK position.
2. Remove the battery cover.
3. Disconnect the negative battery cable and wait for **1 min or more** . (See BATTERY REMOVAL/INSTALLATION [LF] .)
4. Remove in the order indicated in Fig. 23 .

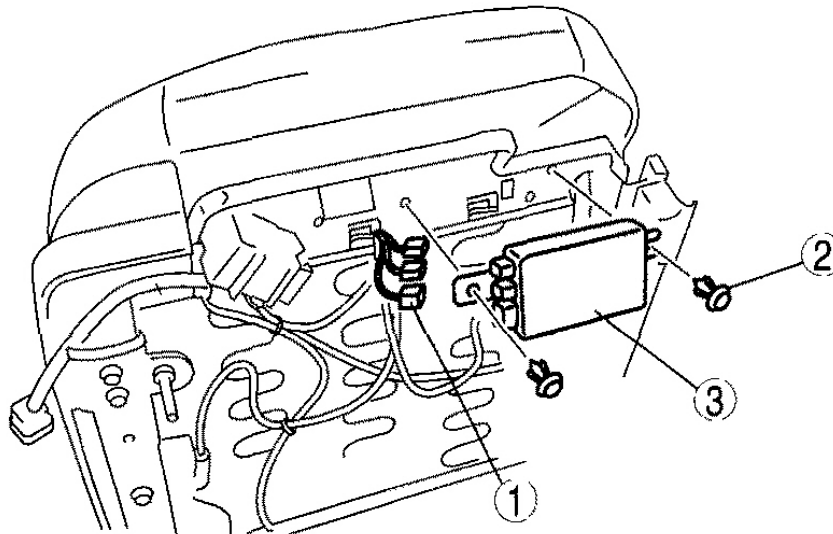

E5U810ZW5015

1	Connector
2	Fasner
3	Seat weight sensor control module

**Fig. 23: Removing/Installing Seat Weight Sensor Control Module**  
 Courtesy of MAZDA MOTORS CORP.

5. Install in the reverse order of removal.

## SEAT WEIGHT SENSOR CALIBRATION

**CAUTION:**

- If any of the following work is performed, perform the seat weight sensor calibration using the WDS or equivalent.
  - Replacement with a new seat weight sensor
  - Replacement with a new seat weight sensor control module
  - Replacement with new passenger-side seat parts
  - Disassembly of the passenger-side seat
- If any of the following work is performed, perform the seat weight sensor inspection using the WDS or equivalent. (See SEAT WEIGHT SENSOR INSPECTION .)
  - Removal of the passenger-side seat
  - Loosening and retightening of passenger's seat fixing bolts

- Or, the vehicle is involved in a collision

1. Have two **20 kg {44 lb}** weights ready to use.
2. Connect the WDS or equivalent to the DLC-2 (16-pin).

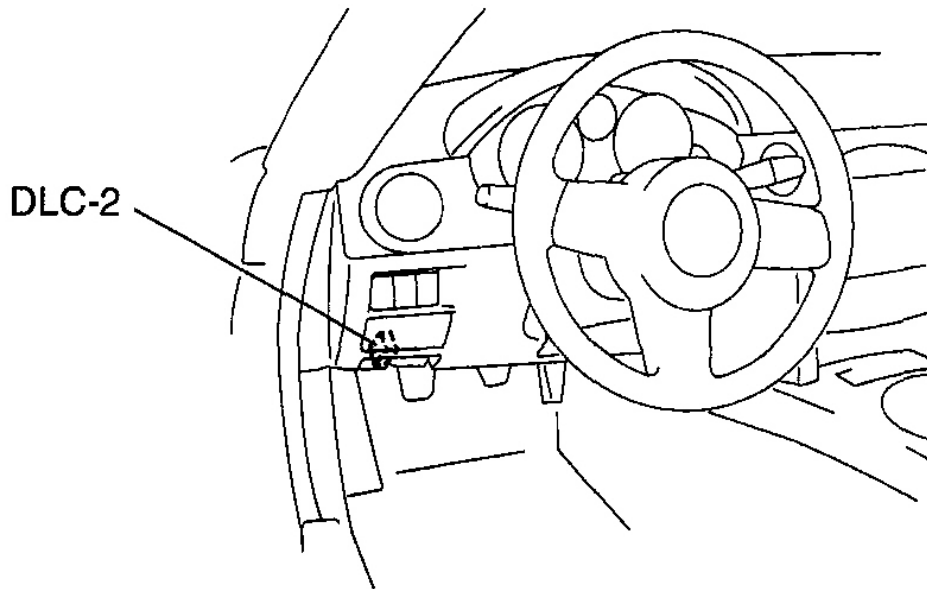

E5U802ZW5100

**Fig. 24: Identifying DLC-2 Location**  
Courtesy of MAZDA MOTORS CORP.

3. Select "Body" from the menu.
4. Select "Restraints".
5. Select "Seat Weight Sensor ReZero Procedure".
6. Perform calibration following the procedures on the WDS or equivalent screen.

**NOTE:**

- When "Lightly pat the passenger seat cushion" is displayed on the WDS or equivalent screen, lightly pat horizontally approx. five times on the headrest or upper side of the seat back trim of the passenger-side front seat.

## SEAT WEIGHT SENSOR INSPECTION

**CAUTION:**

- If any of the following work is performed, perform the seat weight

sensor inspection using the WDS or equivalent.

- Removal of the passenger-side seat
- Loosening and retightening of passenger's seat fixing bolts
- Or, the vehicle is involved in a collision
- If any of the following work is performed, perform the seat weight sensor calibration using the WDS or equivalent. (See SEAT WEIGHT SENSOR CALIBRATION .)
  - Replacement with a new seat weight sensor
  - Replacement with a new seat weight sensor control module
  - Replacement with new passenger-side seat parts
  - Disassembly of the passenger-side seat

1. Connect the WDS or equivalent to the DLC-2 (16-pin).

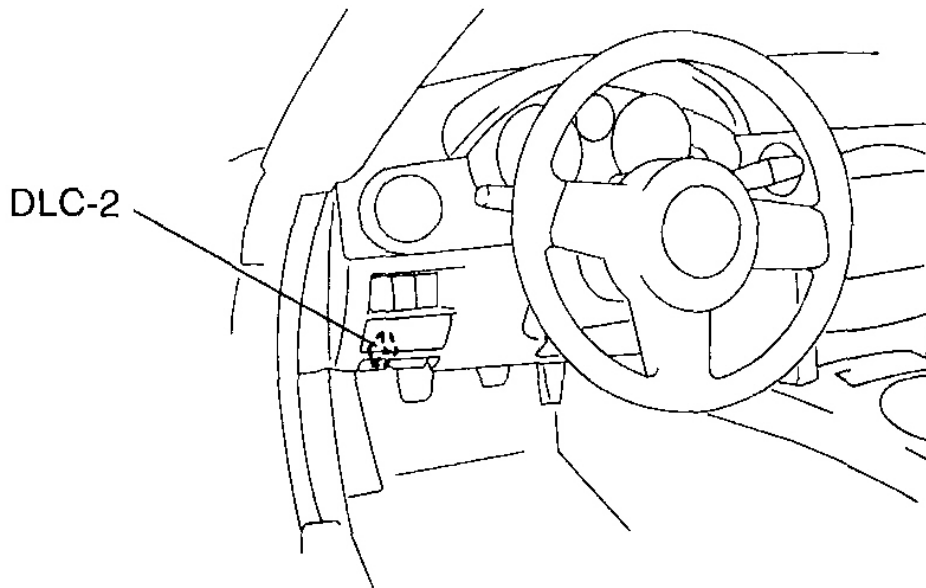

E5U802ZW5100

**Fig. 25: Identifying DLC-2 Location**  
Courtesy of MAZDA MOTORS CORP.

2. Select "Body" from the menu.
3. Select "Restraints".
4. Select "Seat Weight Sensor ReZero Procedure".
5. Perform inspection following the procedures on the WDS or equivalent screen.

## PASSENGER AIR BAG DEACTIVATION (PAD) SWITCH REMOVAL/INSTALLATION

1. Remove the battery cover.
2. Disconnect the negative battery cable. (See **BATTERY REMOVAL/INSTALLATION [LF]** .)
3. Remove the side panel. (See **SIDE PANEL REMOVAL/INSTALLATION** .)
4. Disconnect the connector.
5. Remove the PAD switch.

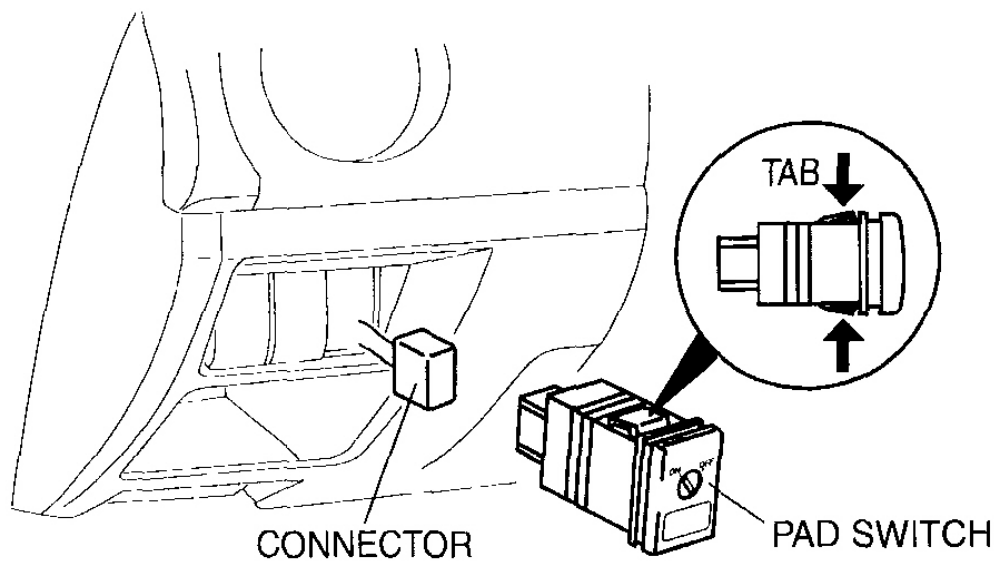

E5U810ZW5034

**Fig. 26: Removing/Installing Passenger Air Bag Deactivation (PAD) Switch**  
Courtesy of MAZDA MOTORS CORP.



6. Install in the reverse order of removal.
7. Turn the ignition switch to the ON position.
8. Verify that the air bag system warning light illuminates for **approx. 6 s** and goes out.
  - If the air bag system warning light does not operate normally, refer to **RESTRAINTS -- ON-BOARD DIAGNOSTIC** system (air bag system) and perform inspection of the system.

## PASSENGER AIR BAG DEACTIVATION (PAD) SWITCH INSPECTION

1. Remove the PAD switch. (See **PASSENGER AIR BAG DEACTIVATION (PAD) SWITCH REMOVAL/INSTALLATION** .)

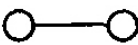
2. Verify that the continuity between the PAD switch terminals is as indicated in **Fig. 27** .
  - If not as indicated in **Fig. 27** , replace the PAD switch.

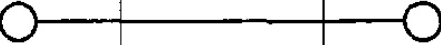
 Continuity

Switch position	Terminal		
	C	D	E
PASS AIRBAG OFF			
PASS AIRBAG ON			

B3E0810W019

**Fig. 27: PAD Switch Continuity Table**  
 Courtesy of MAZDA MOTORS CORP.

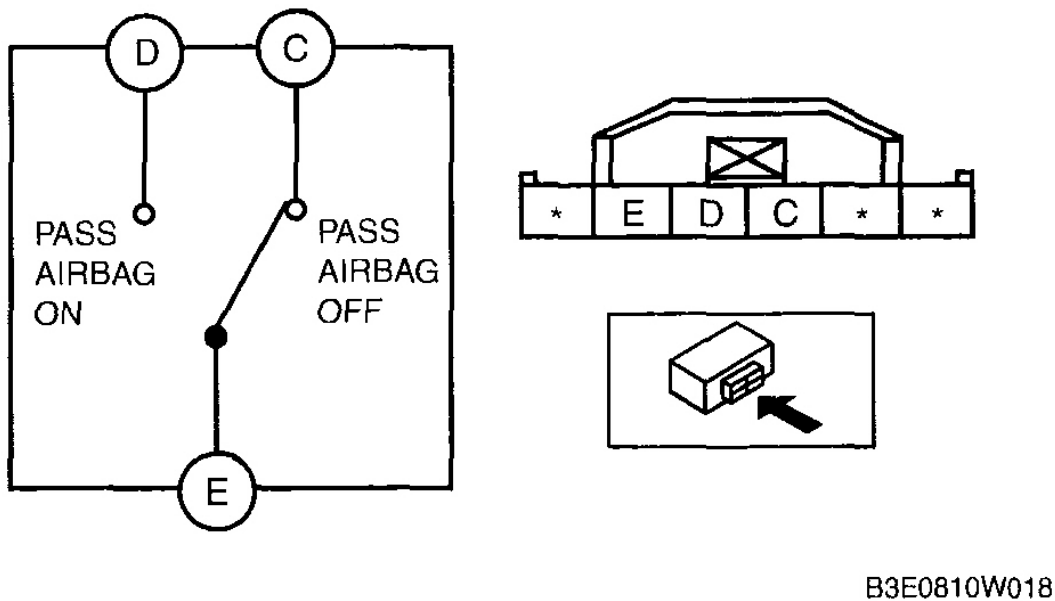

**Fig. 28: Inspecting Passenger Air Bag Deactivation (PAD) Switch Connector Terminals**  
 Courtesy of MAZDA MOTORS CORP.

## SIDE AIR BAG SENSOR REMOVAL/INSTALLATION

### WARNING:

- Handling the side air bag sensor improperly can accidentally operate (deploy) the air bag module, which may seriously injure you. Read the air bag system service warnings and cautions before handling the side air bag sensor. (See **AIR BAG SYSTEM SERVICE WARNINGS** .) (See **AIR BAG SYSTEM SERVICE CAUTIONS** .)

1. Turn the ignition switch to the LOCK position.
2. Remove the battery cover.
3. Disconnect the negative battery cable and wait for **1 min or more** . (See **BATTERY REMOVAL/INSTALLATION [LF]** .)
4. Remove the quarter trim. (See **QUARTER TRIM REMOVAL/INSTALLATION** .)
5. Remove the scuff plate. (See **SCUFF PLATE REMOVAL/INSTALLATION** .)
6. Remove the tire house trim. (See **TIRE HOUSE TRIM REMOVAL/INSTALLATION** .)
7. Remove in the order indicated in **Fig. 29** .

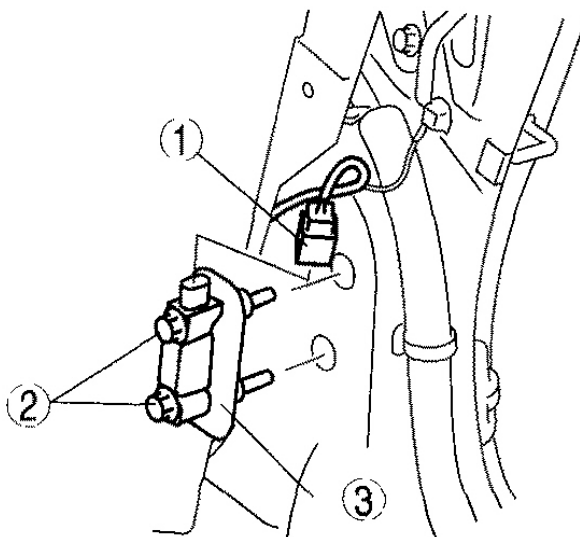

E5U810ZW5016

1	Connector
2	Bolt
3	Side air bag sensor

**Fig. 29: Removing/Installing Side Air Bag Sensor**  
 Courtesy of MAZDA MOTORS CORP.

8. Install in the reverse order of removal.
9. Turn the ignition switch to the ON position and hold for **5 s or more** .
10. Verify that the air bag system warning light illuminates for **approx. 6 s** and goes out.
  - If the air bag system warning light does not operate normally, refer to **RESTRAINTS -- ON-BOARD DIAGNOSTIC** system (air bag system) and perform inspection of the system.

## CLOCK SPRING REMOVAL/INSTALLATION

1. Remove the battery cover.
2. Disconnect the negative battery cable. (See **BATTERY REMOVAL/INSTALLATION [LF]** .)
3. Remove the following parts:
  1. Driver-side air bag module (See **DRIVER-SIDE AIR BAG MODULE REMOVAL/INSTALLATION** .)
  2. Steering wheel (See **STEERING WHEEL AND COLUMN REMOVAL/INSTALLATION** .)
  3. Column cover (See **COLUMN COVER REMOVAL/INSTALLATION** .)
4. Remove in the order indicated in **Fig. 30** .

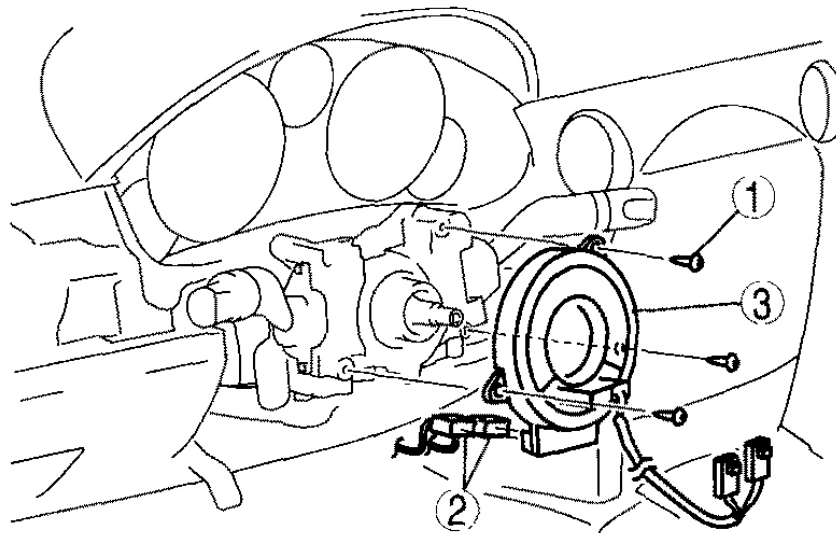

E5U810ZW5017

1	Screw
2	Connector
3	Clock spring

**Fig. 30: Clock Spring Removing/Installing Steps**



## 2007 Mazda MX-5 Miata Sport

2007 RESTRAINTS Air Bag System - MX-5 Miata

### Courtesy of MAZDA MOTORS CORP.

5. Install in the reverse order of removal.
6. Turn the ignition switch to the ON position.
7. Verify that the air bag system warning light illuminates for **approx. 6 s** and goes out.
  - If the air bag system warning light does not operate normally, refer to **RESTRAINTS -- ON-BOARD DIAGNOSTIC** system (air bag system) and perform inspection of the system.

### CLOCK SPRING INSTALLATION NOTE

- CAUTION:**
- If the clock spring is not adjusted, the spring wire in the clock spring could over-wind and break when the steering wheel is turned. Always adjust the clock spring after installing it.

1. Adjust the clock spring after installing it. (See **CLOCK SPRING ADJUSTMENT** .)

### CLOCK SPRING ADJUSTMENT

- NOTE:**
- The adjustment procedure is also specified on the caution label of the clock spring.

1. Set the front tires straight-ahead.

- CAUTION:**
- The clock spring will break if over-wound. Do not forcibly turn the clock spring.

2. Turn the clock spring clockwise until it stops.

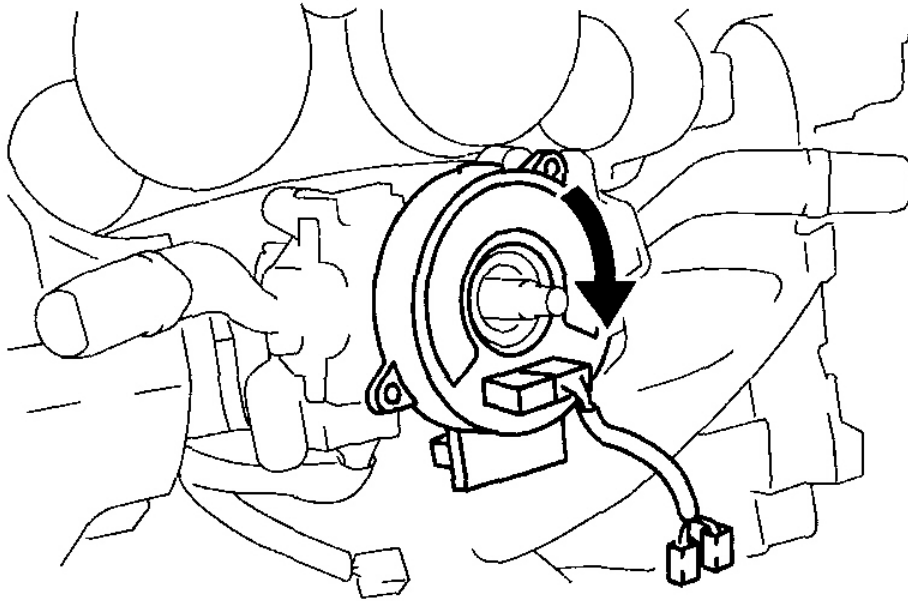

E5U810ZW5018

**Fig. 31: Turning Clock Spring Clockwise**  
Courtesy of MAZDA MOTORS CORP.

3. From the stopped position, turn the clock spring counterclockwise **2 3/4 turns** .

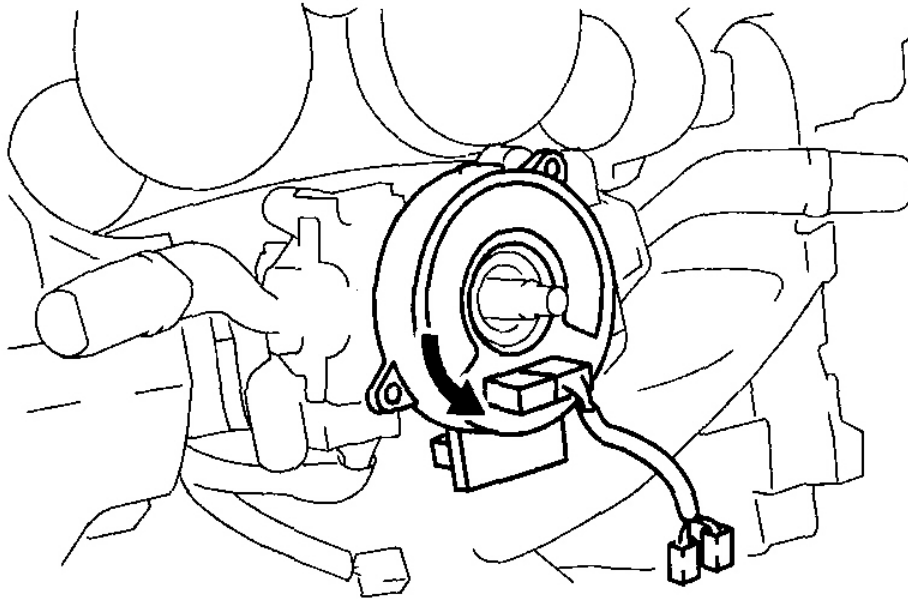

E5U810ZW5019

**Fig. 32: Turning Clock Spring Counterclockwise 2 3/4 Turns**  
Courtesy of MAZDA MOTORS CORP.

4. Align the mark on the clock spring with the mark on the outer housing.

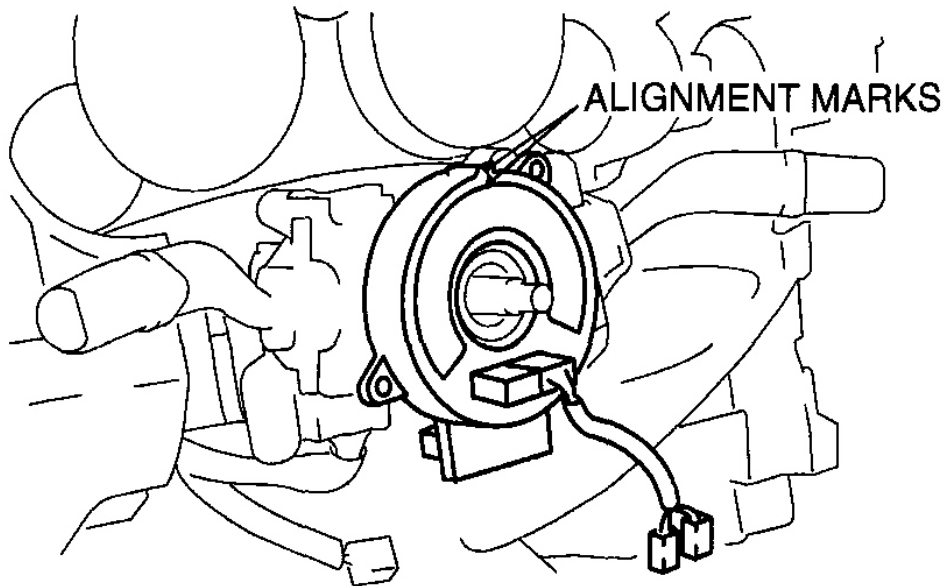

E5U810ZW5020

**Fig. 33: Aligning Mark On Clock Spring With Mark On Outer Housing**  
Courtesy of MAZDA MOTORS CORP.

## CLOCK SPRING INSPECTION

1. Remove the driver-side air bag module. (See **DRIVER-SIDE AIR BAG MODULE REMOVAL/INSTALLATION** .)
2. Remove the steering wheel. (See **STEERING WHEEL AND COLUMN REMOVAL/INSTALLATION** .)
3. Remove the clock spring. (See **CLOCK SPRING REMOVAL/INSTALLATION** .)
4. Verify that the continuity is as indicated in **Fig. 34** .
  - If not as indicated in **Fig. 34** , replace the clock spring.

### NOTE:

- When the vehicle-side connector for the clock spring is disconnected, terminals 1A, 1B, 1C and 1D are shorted to prevent unexpected operation (deployment) of the air bag module.

# 2007 Mazda MX-5 Miata Sport

## 2007 RESTRAINTS Air Bag System - MX-5 Miata

○—○ : Continuity

Test condition	1A	1B	1C	1D	2A	2B	2C	2D	2E	2F	2G	2H	3A	3B	4A	4B	5A	5B	5C	5D	5E	5F	5G	5H		
Under any condition	○	○													○	○										
			○	○										○	○											
					○													○								
						○													○							
							○													○						
								○													○					

CHU0810W010

**Fig. 34: Clock Spring Continuity Reference Table**  
 Courtesy of MAZDA MOTORS CORP.

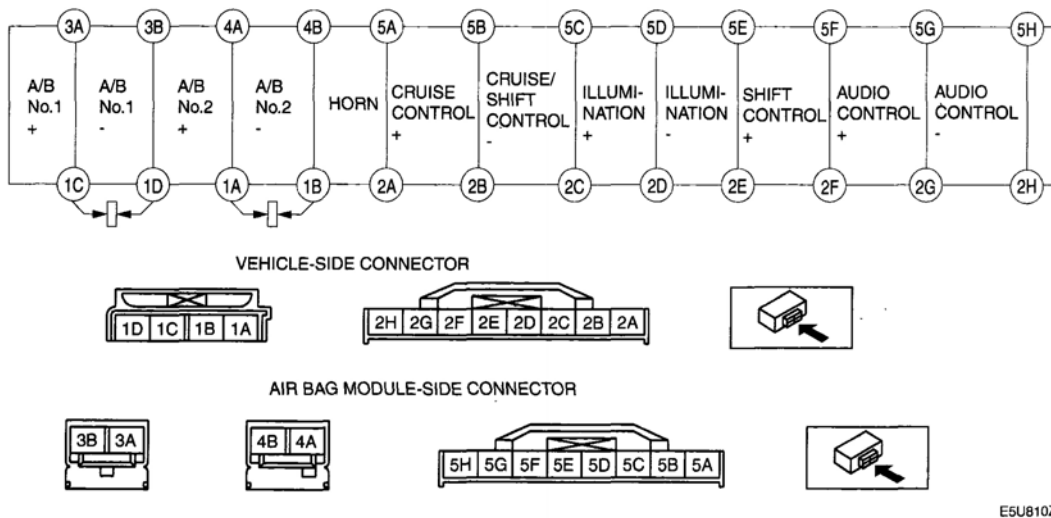

**Fig. 35: Identifying Clock Spring Connector Terminals**  
 Courtesy of MAZDA MOTORS CORP.

## AIR BAG MODULE AND PRE-TENSIONER SEAT BELT DEPLOYMENT PROCEDURES

### WARNING:

- A live (undeployed) air bag module or pre-tensioner seat belt may accidentally operate (deploy) when it is disposed of and cause serious injury. Do not dispose of a live (undeployed) air bag module and pre-tensioner seat belt. If the SSTs (Deployment tool and Adapter harness) are not available, consult the nearest Mazda representative for assistance.

- CAUTION:**
- **Deploying the air bag modules and pre-tensioner seat belts inside the vehicle may cause damage to the vehicle interior. When the vehicle is not to be scrapped, always deploy the air bag modules and pre-tensioner seat belts outside the vehicle.**
  - If the vehicle is to be scrapped, or when disposing of any air bag modules or pre-tensioner seat belts, operate (deploy) them inside the vehicle by following the deployment procedure below and using the **SST** (Deployment tool).
  - When disposing of an operated (deployed) air bag module and pre-tensioner seat belt, refer to **AIR BAG MODULE AND PRE-TENSIONER SEAT BELT DISPOSAL PROCEDURES** .

### DEPLOYMENT PROCEDURE FOR INSIDE OF VEHICLE

1. Inspect the **SST** (Deployment tool). (See **INSPECTION OF SST (DEPLOYMENT TOOL)** .)
2. Move the vehicle to an open space, away from strong winds, and close all of the vehicle doors and windows.
3. Turn the ignition switch to the LOCK position.
4. Remove the battery cover.
5. Disconnect the negative battery cable and wait for **1 min or more** . (See **BATTERY REMOVAL/INSTALLATION [LF]** .)
6. Follow the procedure below for operating (deploying) the applicable air bag module or pre-tensioner seat belt.

### DRIVER-SIDE AIR BAG MODULE

- WARNING:**
- **The driver-side air bag module is a dual inflator type. If one inflator is forced to operate (deploy), the other may operate (deploy) accidentally. To prevent injury while disposing of the air bag module, make sure to operate (deploy) both driver-side air bag module inflators simultaneously, following the procedure below.**

- NOTE:**
- **The SSTs , two types of adapter harnesses (for inflators No.1 and No.2) and two deployment tools are to be used to operate (deploy) the driver-side air bag module.**

1. Remove the driver-side air bag module. (See **DRIVER-SIDE AIR BAG MODULE REMOVAL/INSTALLATION** .)
2. Connect the **SSTs** (Adapter harness) to the driver-side air bag module as shown in **Fig. 36** .
3. Install the driver-side air bag module. (See **DRIVER-SIDE AIR BAG MODULE REMOVAL/INSTALLATION** .)

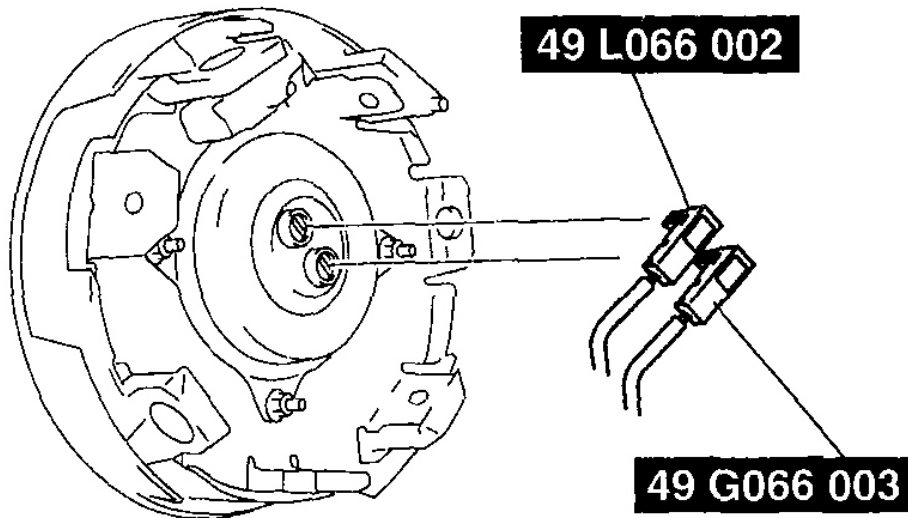

E5U810ZW5023

**Fig. 36: Connecting SSTs (Adapter Harness) To Driver-Side Air Bag Module**  
Courtesy of MAZDA MOTORS CORP.

4. Connect the SSTs (Deployment tool) to the SSTs (Adapter harness).

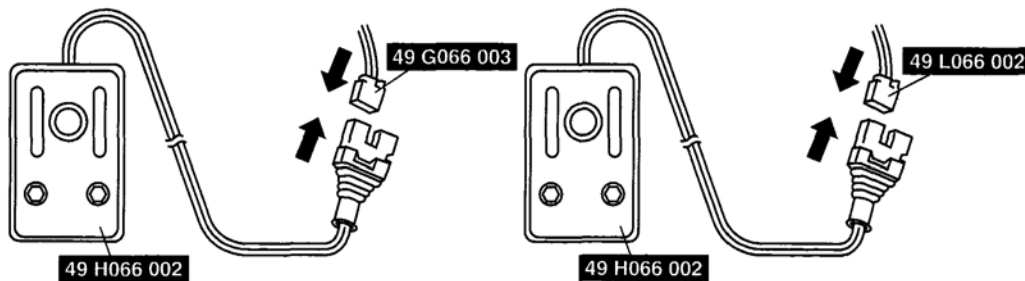

B3E0810W020

**Fig. 37: Connecting SSTs (Deployment tool) To SSTs (Adapter Harness)**  
Courtesy of MAZDA MOTORS CORP.

5. Connect both SSTs (Deployment tool) to the battery. Connect the power supply red clip to the positive battery terminal, and the black clip to the negative battery terminal.
6. Verify that the red lamp on both SSTs (Deployment tool) is illuminated.
7. Verify that all persons are standing **at least 6 m {20 ft}** away from the vehicle.
8. Press the activation switch on the SST (Deployment tool) connected with 49 L066 002 (a yellow

connector) of the **SST** (Adapter harness), and **after 3 s** , press the activation switch on the other **SST** (Deployment tool) to operate (deploy) the air bag module (both inflators).

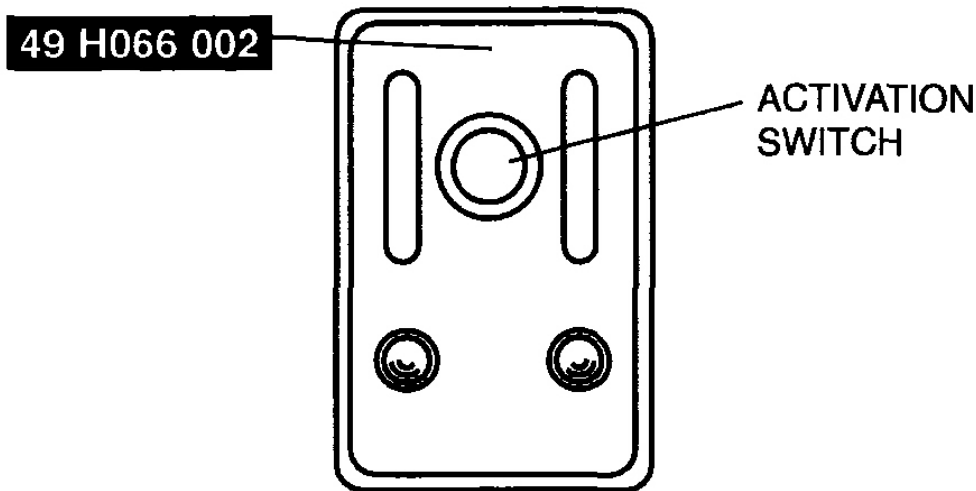

A6E8130W028

**Fig. 38: Identifying Activation Switch**  
Courtesy of MAZDA MOTORS CORP.

**WARNING:**

- Verify that air bag module operation (explosive) sound occurs twice. If no operation (explosive) sound was heard or a single operation (explosive) sound was heard, both inflators would not have operated (deployed) properly. This may cause serious injury if the air bag module operates (deploy) unexpectedly. If the two operation (explosive) sounds are not heard, perform Step 8 again. If a total of two operation (explosive) sounds cannot be verified even though step 8 is performed again, leave the air bag module alone for 30 min or more before approaching it again.
- The air bag module is very hot immediately after it is operated (deployed). You can get burned. Do not touch the air bag module for at least 15 min after deployment.

9. Disconnect the **SSTs** (Deployment tool) from the **SSTs** (Adapter harness).

**PASSENGER-SIDE AIR BAG MODULE**

**WARNING:**

- The passenger-side air bag module is a dual inflator type. If one



inflator is forced to operate (deploy), the other may operate (deploy) accidentally. To prevent injury while disposing of the air bag module, make sure to operate (deploy) both passenger-side air bag module inflators simultaneously, following the procedure below.

**NOTE:**

- The SSTs , two types of adapter harnesses (for inflators No.1 and No.2) and two deployment tools are to be used to operate (deploy) the passenger-side air bag module.

1. Remove the glove compartment. (See **GLOVE COMPARTMENT REMOVAL/INSTALLATION** .)
2. Disconnect the passenger-side air bag module connector.
3. Connect the SSTs (Adapter harness) to the passenger-side air bag module as shown in **Fig. 39** .
4. Connect the SSTs (Deployment tool) to the SSTs (Adapter harness).

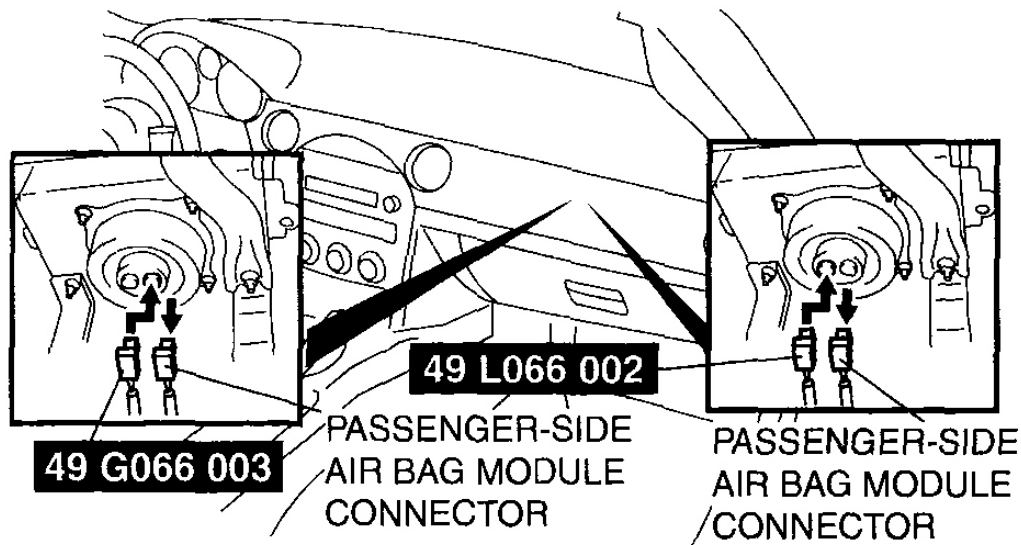

E5U810ZW5024

**Fig. 39: Connecting SSTs (Adapter Harness) To Passenger-Side Air Bag Module**  
Courtesy of MAZDA MOTORS CORP.

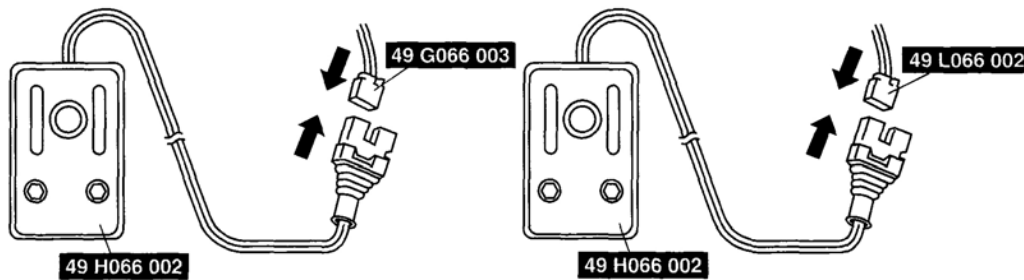

B3E0810W020

**Fig. 40: Connecting SSTs (Deployment Tool) To SSTs (Adapter Harness)**  
 Courtesy of MAZDA MOTORS CORP.

5. Connect both **SSTs** (Deployment tool) to the battery. Connect the power supply red clip to the positive battery terminal, and the black clip to the negative battery terminal.
6. Verify that the red lamp on both **SSTs** (Deployment tool) is illuminated.
7. Verify that all persons are standing **at least 6 m {20 ft}** away from the vehicle.
8. Press the activation switch on the **SST** (Deployment tool) connected with 49 L066 002 (a yellow connector) of the **SST** (Adapter harness), and **after 3 s** , press the activation switch on the other **SST** (Deployment tool) to operate (deploy) the air bag module (both inflators).

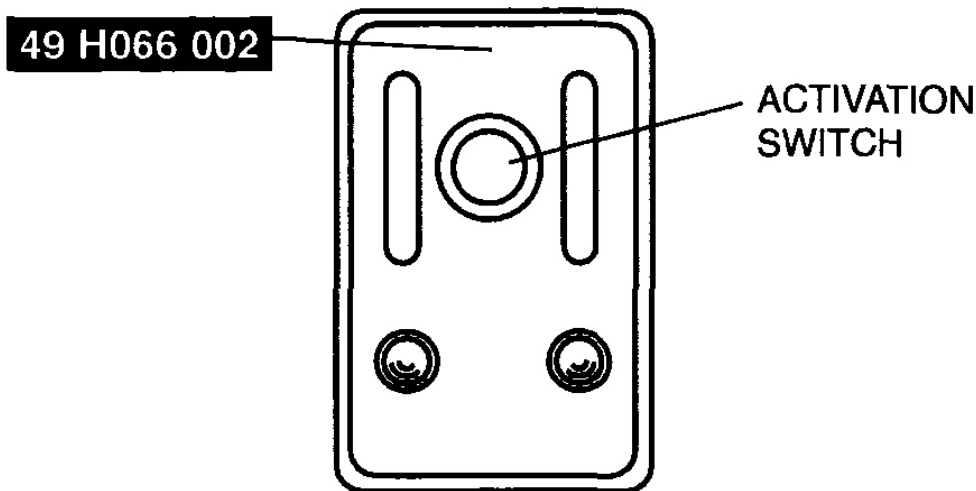

A6E8130W028

**Fig. 41: Identifying Activation Switch**  
 Courtesy of MAZDA MOTORS CORP.

**WARNING:**

- Verify that air bag module operation (explosive) sound occurs twice. If no operation (explosive) sound was heard or a single operation (explosive) sound was heard, both inflators would not have operated (deployed) properly. This may cause serious injury if the air bag module operates (deploy) unexpectedly. If the two operation (explosive) sounds are not heard, perform Step 8 again. If a total of two operation (explosive) sounds cannot be verified even though Step 8 is performed again, leave the air bag module alone for 30 min or more before approaching it again.
- The air bag module is very hot immediately after it is operated (deployed). You can be burned. Do not touch the air bag module for at least 15 min after deployment.

9. Disconnect the SSTs (Deployment tool) from the SSTs (Adapter harness).

**SIDE AIR BAG MODULE**

1. Disconnect the seat connector.
2. Connect the SST (Adapter harness) to the side air bag module as shown in **Fig. 42** .

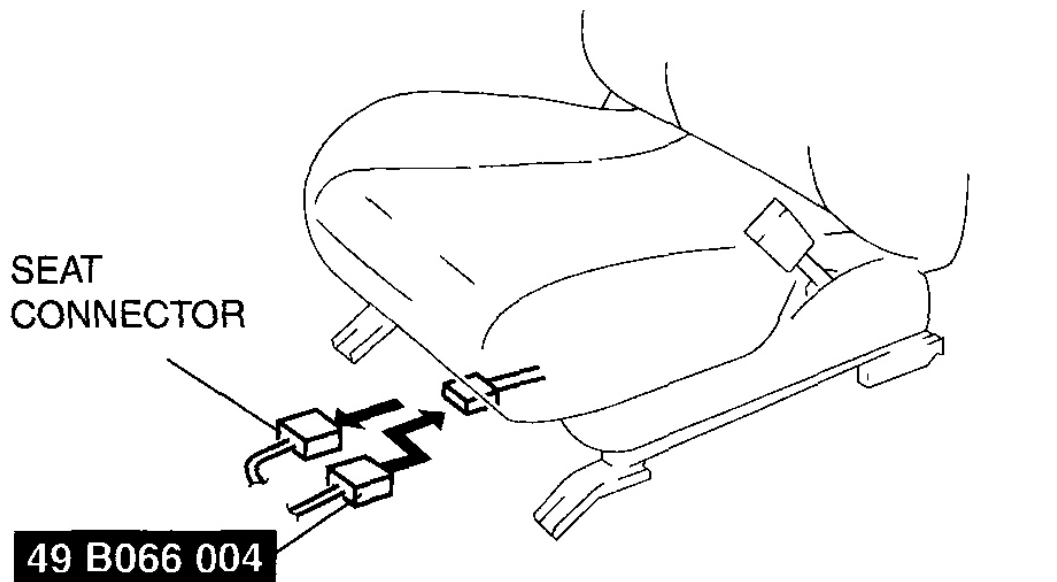

E5U810ZW5240

**Fig. 42: Connecting SST (Adapter Harness) To Side Air Bag Module**  
Courtesy of MAZDA MOTORS CORP.

3. Connect the **SST** (Deployment tool) to the **SST** (Adapter harness).
4. Connect the **SST** (Deployment tool) to the battery. Connect the power supply red clip to the positive battery terminal, and the black clip to the negative battery terminal.
5. Verify that the red lamp on the **SST** (Deployment tool) is illuminated.
6. Verify that all persons are standing **at least 6 m {20 ft}** away from the vehicle.

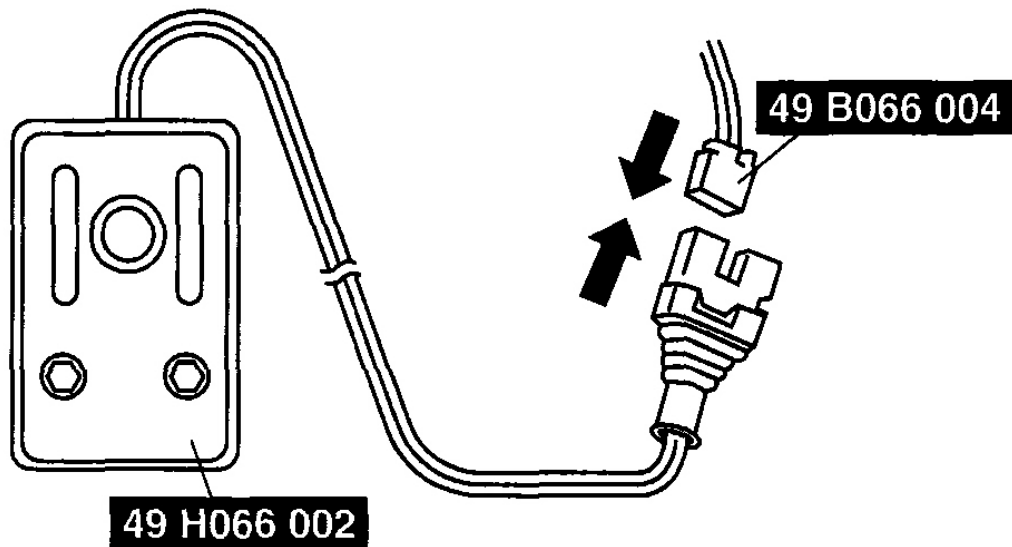

E5U810ZW5139

**Fig. 43: Connecting SST (Deployment Tool) To SST (Adapter Harness)**  
Courtesy of MAZDA MOTORS CORP.

7. Press the activation switch on the **SST** (Deployment tool) to operate (deploy) the side air bag module.
8. Disconnect the **SSTs** (Deployment tool) from the **SSTs** (Adapter harness).

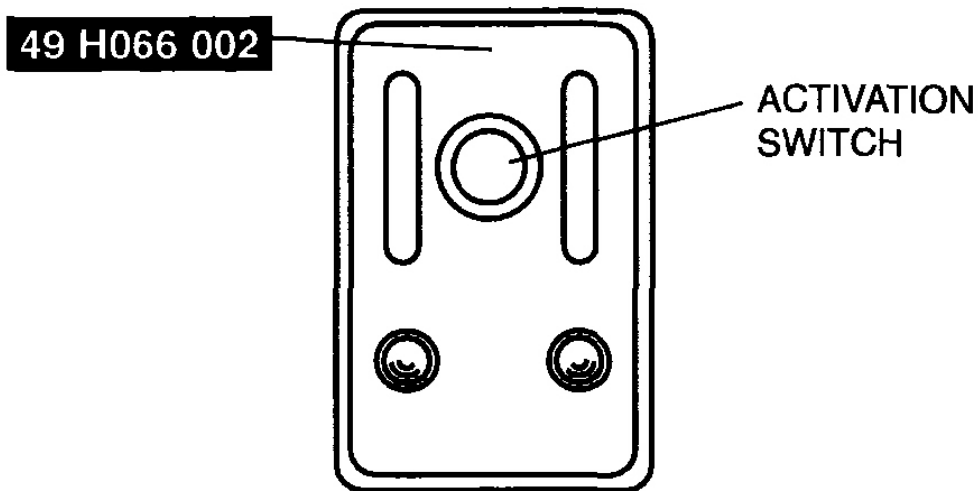

A6E8130W028

**Fig. 44: Identifying Activation Switch**  
Courtesy of MAZDA MOTORS CORP.

#### **PRE-TENSIONER SEAT BELT**

1. Remove the back trim. (See **BACK TRIM REMOVAL/INSTALLATION** .)
2. Remove the pre-tensioner seat belt and connect the **SST** (Adapter harness) as shown in **Fig. 45** . (See **SEAT BELT REMOVAL/INSTALLATION** .)

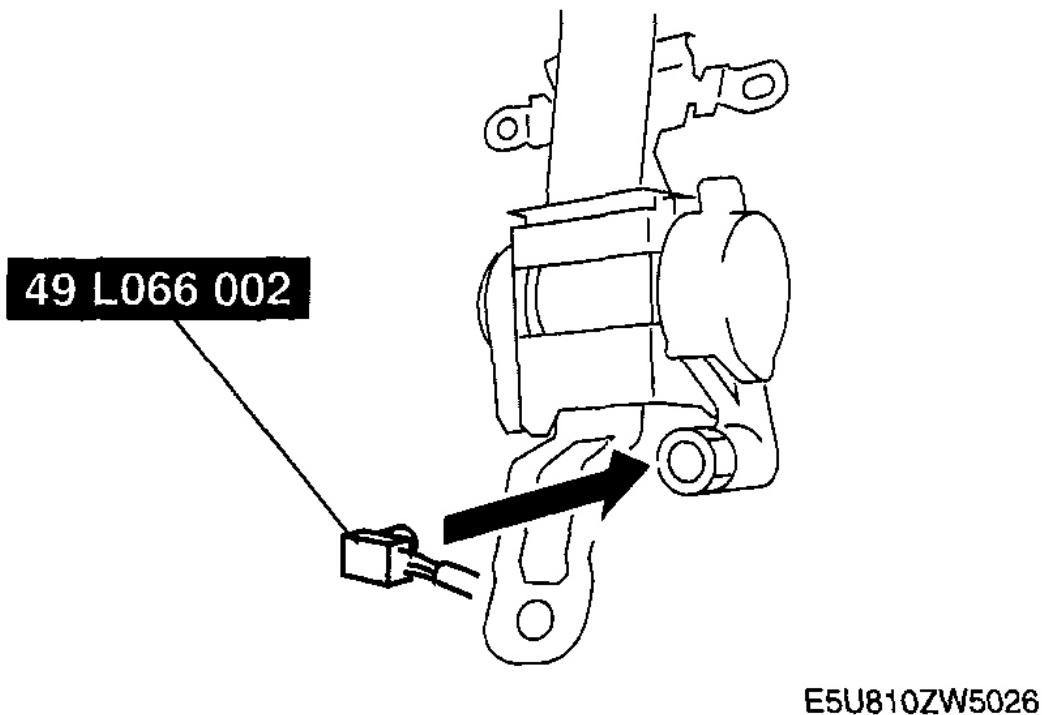

**Fig. 45: Removing Pre-Tensioner Seat Belt & Connect SST (Adapter Harness)**  
Courtesy of MAZDA MOTORS CORP.

3. Install the pre-tensioner seat belt.
4. Connect the **SST** (Deployment tool) to the **SST** (Adapter harness).
5. Connect the **SST** (Deployment tool) to the battery. Connect the power supply red clip to the positive battery terminal, and the black clip to the negative battery terminal.
6. Verify that the red lamp on the **SST** (Deployment tool) is illuminated.
7. Verify that all persons are standing **at least 6 m {20 ft}** away from the vehicle.

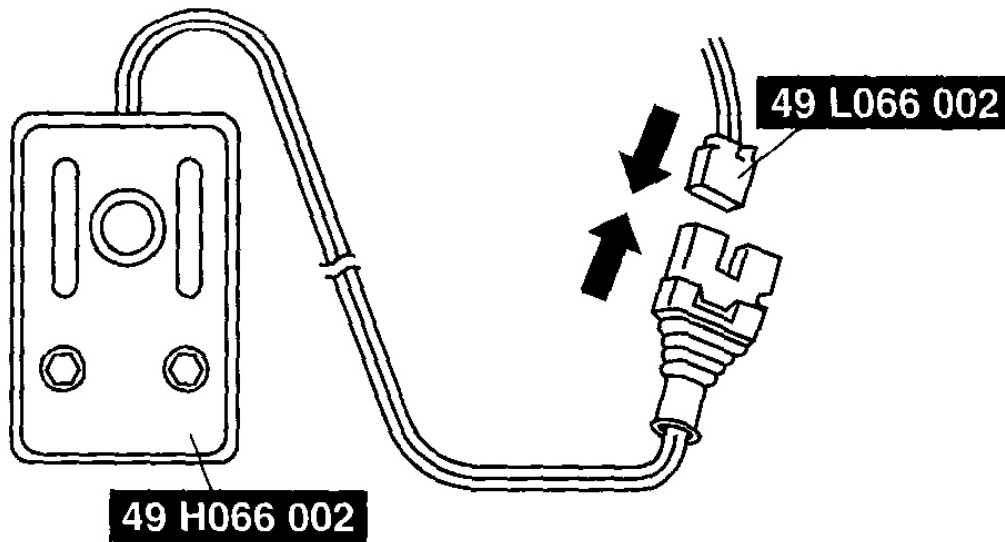

B3E0810W027

**Fig. 46: Connecting SST (Deployment Tool) To SST (Adapter Harness)**  
Courtesy of MAZDA MOTORS CORP.

8. Press the activation switch on the SST (Deployment tool) to operate (deploy) the pre-tensioner seat belt.

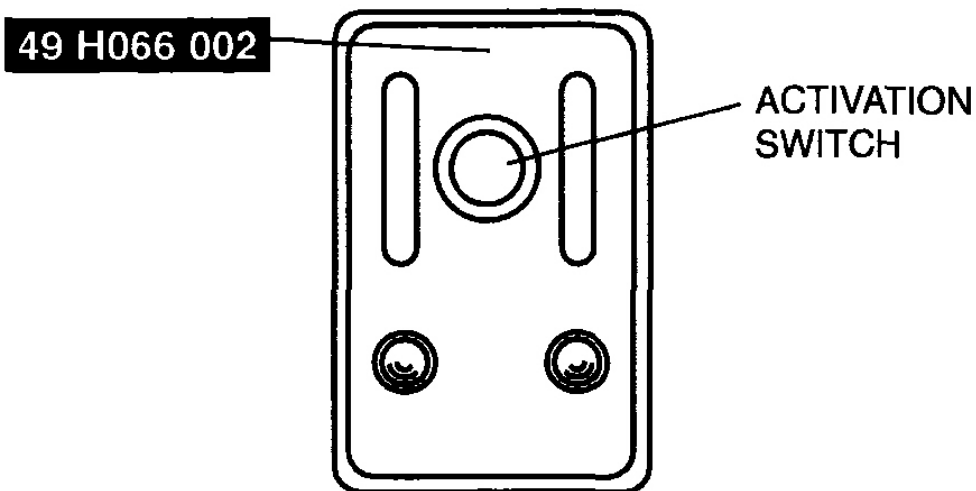

A6E8130W028

**Fig. 47: Identifying Activation Switch**  
Courtesy of MAZDA MOTORS CORP.

9. Disconnect the SSTs (Deployment tool) from the SSTs (Adapter harness).

**DEPLOYMENT PROCEDURE FOR OUTSIDE OF VEHICLE**

1. Inspect the SST (Deployment tool). (See **INSPECTION OF SST (DEPLOYMENT TOOL)** .)
2. Turn the ignition switch to the LOCK position.
3. Remove the battery cover.
4. Disconnect the negative battery cable and wait for **1 min or more** . (See **BATTERY REMOVAL/INSTALLATION [LF]** .)
5. Follow the procedure below for operating (deploying) the applicable air bag module or pre-tensioner seat belt.

**DRIVER-SIDE AIR BAG MODULE**

**WARNING:**

- **The driver-side air bag module is a dual inflator type. If one inflator is forced to operate (deploy), the other may operate (deploy) accidentally. To prevent injury while disposing of the air bag module, make sure to operate (deploy) both driver-side air bag module inflators simultaneously, following the procedure below.**

1. Remove the driver-side air bag module. (See **DRIVER-SIDE AIR BAG MODULE REMOVAL/INSTALLATION** .)
2. Connect the SSTs (Adapter harness) to the driver-side air bag module as shown in **Fig. 48** .



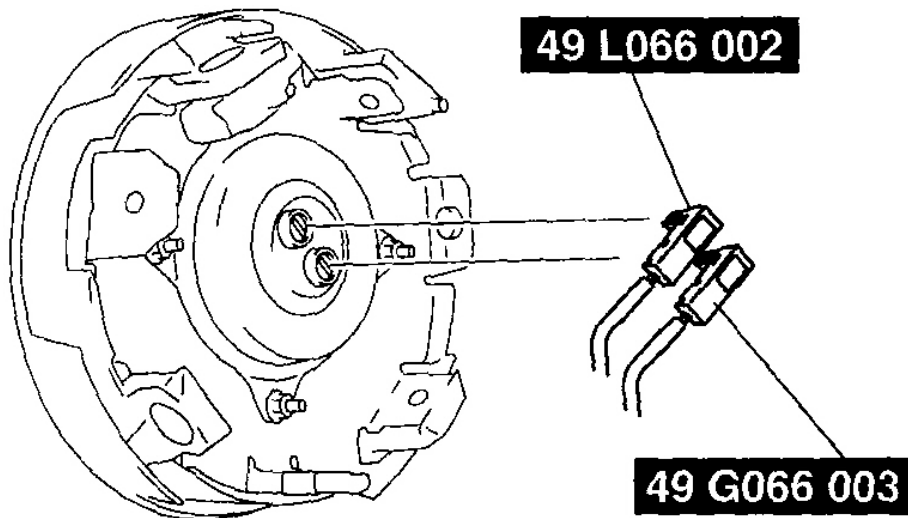

E5U810ZW5023

**Fig. 48: Connecting SSTs (Adapter Harness) To Driver-Side Air Bag Module**  
Courtesy of MAZDA MOTORS CORP.

3. Place the driver-side air bag module on the center of the tire wheel with the padded surface facing up. To secure the air bag module to the tire wheel, wrap a wire (cross section  $1.25 \text{ mm}^2$  {  $0.002 \text{ in}^2$  } or more ) through the wheel and the bolt installation holes of the air bag module **at least 4 times** .

**WARNING:**

- If the air bag module is not properly installed to the tire wheel, serious injury may occur when the module is operated (deployed). When installing the air bag module to the tire wheel, make sure the padded surface is facing up.

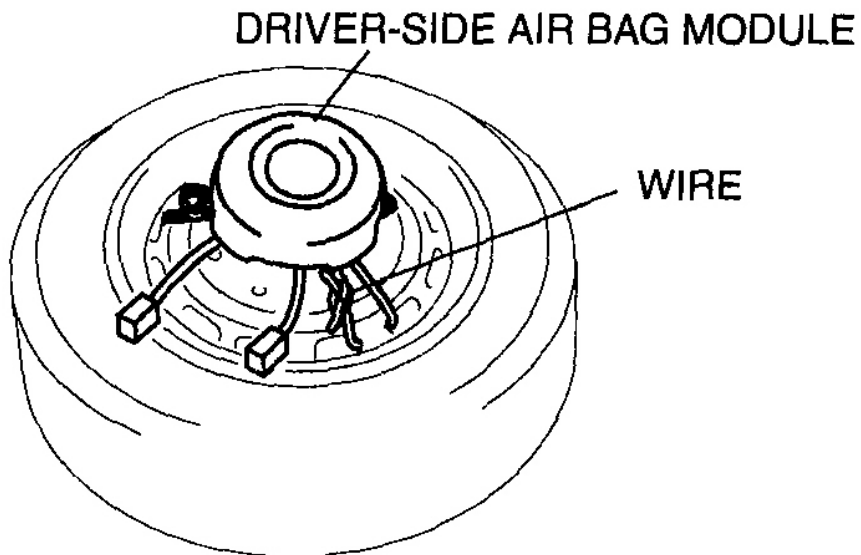

E5U810ZW5027

**Fig. 49: Placing Driver-Side Air Bag Module On Center Of Tire Wheel**  
Courtesy of MAZDA MOTORS CORP.

4. Stack three tires without wheels on top of the tire with the driver-side air bag module, and then stack another tire with a wheel on the very top.

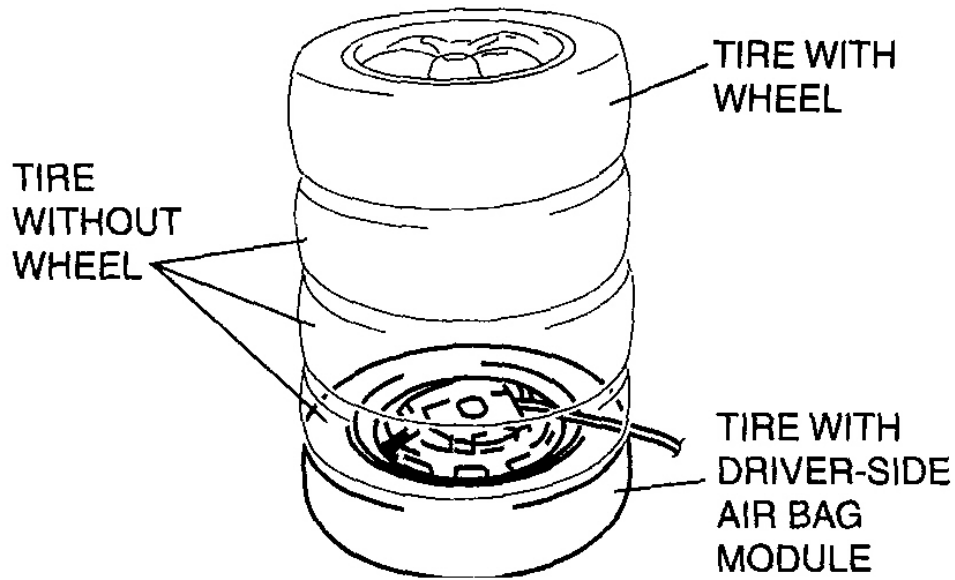

DPE810ZW1036

**Fig. 50: Stacking Tires Without Wheels On Top Of Tire With Driver-Side Air Bag Module**  
Courtesy of MAZDA MOTORS CORP.

5. Secure the tires with wire.

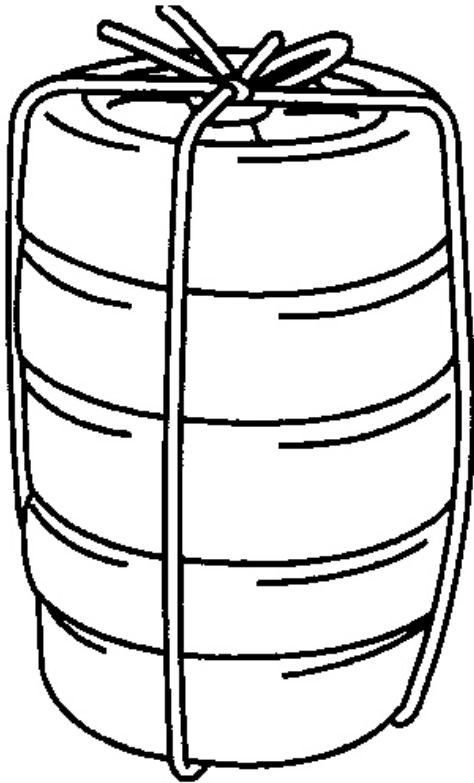

A6E8130W034

**Fig. 51: Tying Tires Together With Wire**  
Courtesy of MAZDA MOTORS CORP.

6. Connect the SSTs (Deployment tool) to the SSTs (Adapter harness).
7. Connect both SSTs (Deployment tool) to the battery. Connect the power supply red clip to the positive battery terminal, and the black clip to the negative battery terminal.
8. Verify that the red lamp on both SSTs (Deployment tool) is illuminated.
9. Verify that all persons are standing **at least 6 m {20 ft}** away from the vehicle.

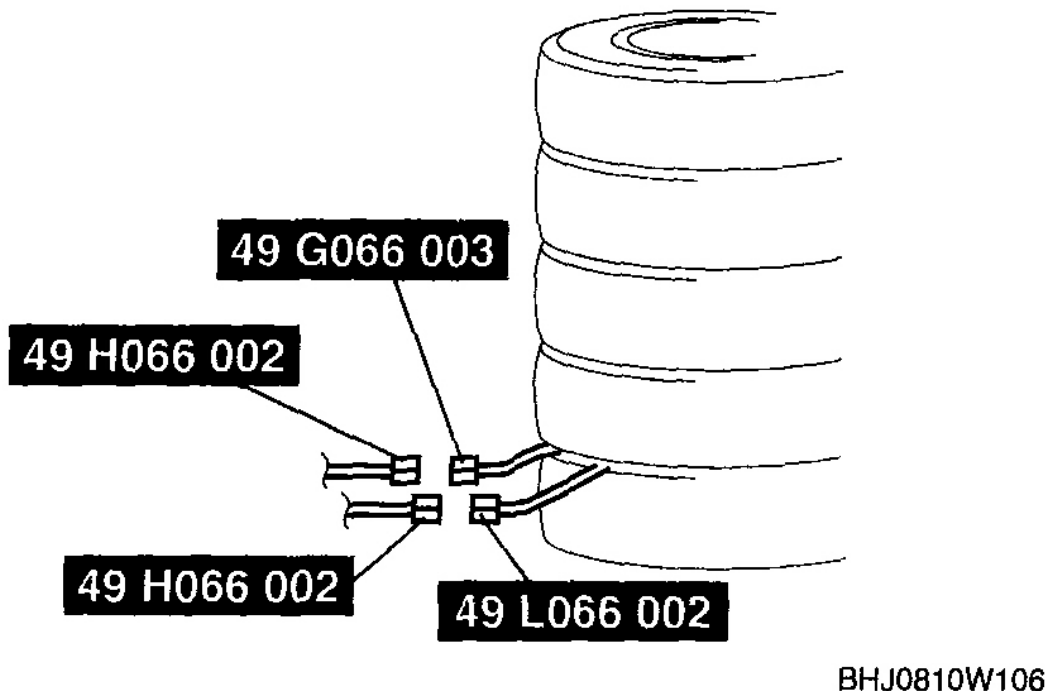
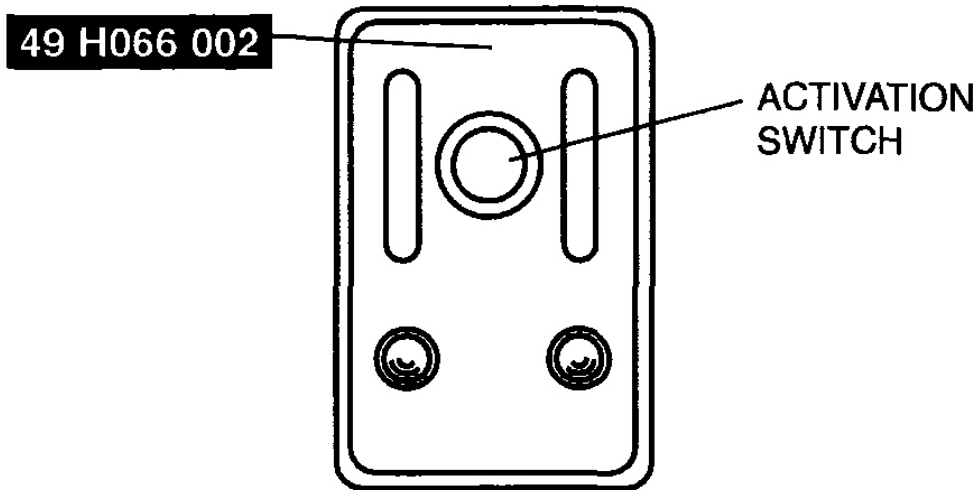

**Fig. 52: Connecting SSTs (Deployment Tool) To SSTs (Adapter Harness)**  
 Courtesy of MAZDA MOTORS CORP.

10. Press the activation switch on the SST (Deployment tool) connected with 49 L066 002 (a yellow connector) of the SST (Adapter harness), and **after 3 s**, press the activation switch on the other SST (Deployment tool) to operate (deploy) the air bag module (both inflators).

**WARNING:**

- Verify that air bag module operation (explosive) sound occurs twice. If no operation (explosive) sound was heard or a single operation (explosive) sound was heard, both inflators would not have operated (deployed) properly. This may cause serious injury if the air bag module operates (deploy) unexpectedly. If the two operation (explosive) sounds are not heard, perform Step 8 again. If a total of two operation (explosive) sounds cannot be verified even though Step 8 is performed again, leave the air bag module alone for 30 min or more before approaching it again.
- The air bag module is very hot immediately after it is operated (deployed). You can be burned. Do not touch the air bag module for at least 15 min after deployment.



A6E8130W028

**Fig. 53: Identifying Activation Switch**  
Courtesy of MAZDA MOTORS CORP.

11. Disconnect the SSTs (Deployment tool) from the SSTs (Adapter harness).

#### **PASSENGER-SIDE AIR BAG MODULE**

**WARNING:**

- The passenger-side air bag module is a dual inflator type. If one inflator is forced to operate (deploy), the other may operate (deploy) accidentally. To prevent injury while disposing of the air bag module, make sure to operate (deploy) both passenger-side air bag module inflators simultaneously, following the procedure below.

1. Remove the passenger-side air bag module. (See **PASSENGER-SIDE AIR BAG MODULE REMOVAL/INSTALLATION** .)
2. Connect the SSTs (Adapter harness) to the passenger-side air bag module as shown in **Fig. 54** .

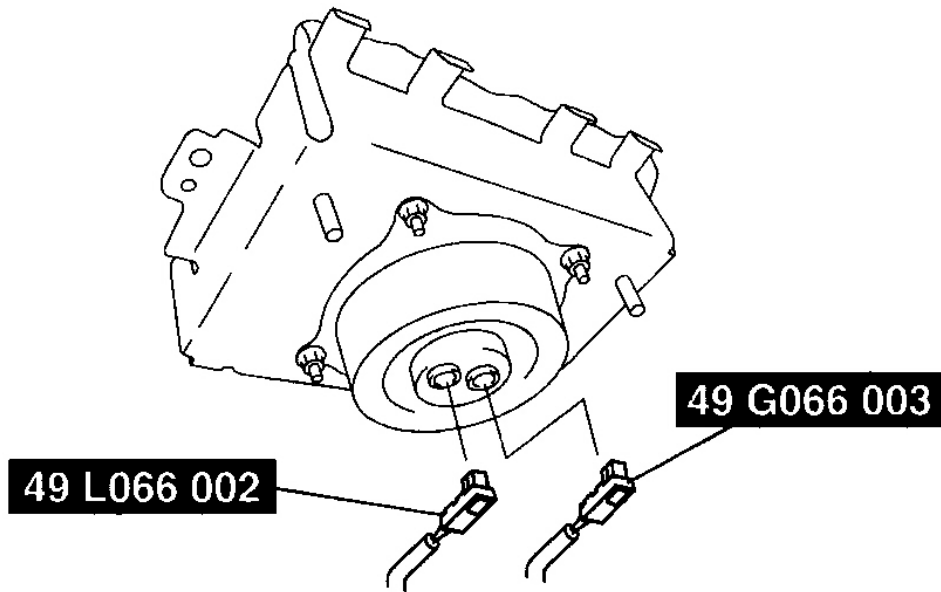

E5U810ZW5028

**Fig. 54: Connecting SSTs (Adapter Harness) To Passenger-Side Air Bag Module**  
Courtesy of MAZDA MOTORS CORP.

3. Place the padded surface of the passenger-side air bag module facing the center of the tire as shown in **Fig. 55** . To secure the air bag module to the tire wheel, wrap a wire (cross section  $1.25 \text{ mm}^2$  {  $0.002 \text{ in}^2$  } or more ) through the tire and the brackets **at least 4 times** as shown in **Fig. 55** .

**WARNING:**

- If the air bag module is not properly secured to the tire, the tires may fall over by the impact of operation (deployment) and cause serious injury. To prevent this, secure the air bag module properly with the padded surface facing the center of the tire.

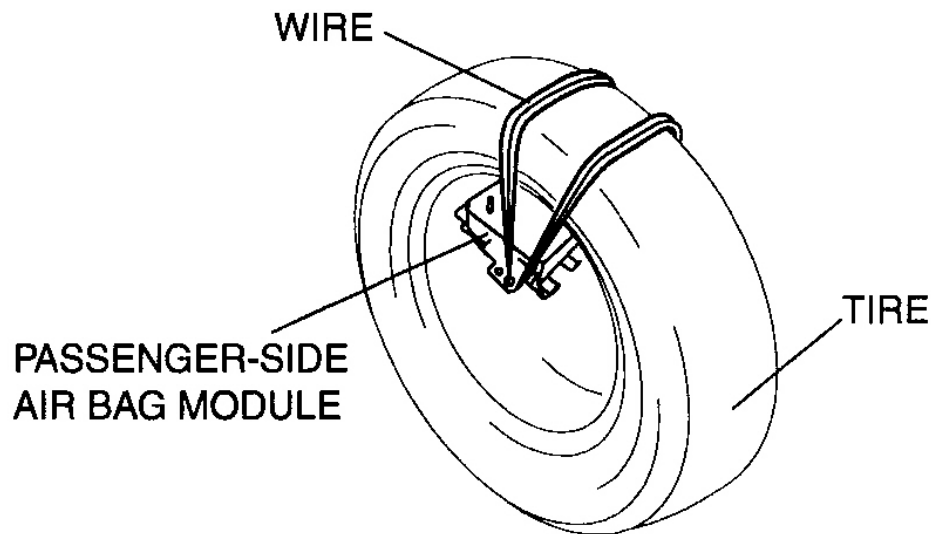

E5U810ZW5032

**Fig. 55: Wrapping Wire Through Tire & Brackets**  
Courtesy of MAZDA MOTORS CORP.

4. Stack the tire with the passenger-side air bag module on top of two tires without wheels. Stack a tire without a wheel on top of the tire with the passenger-side air bag module, and then stack another tire with a wheel on the very top.



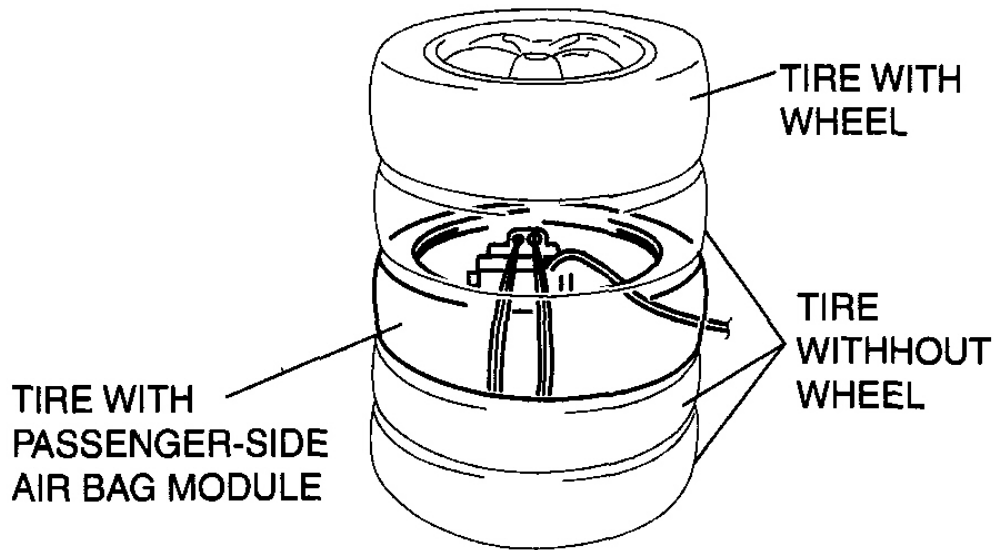

E5U810ZW5030

**Fig. 56: Stacking Tire With Passenger-Side Air Bag Module On Top Of Two Tires Without Wheels**  
Courtesy of MAZDA MOTORS CORP.

5. Secure the tires with wire.

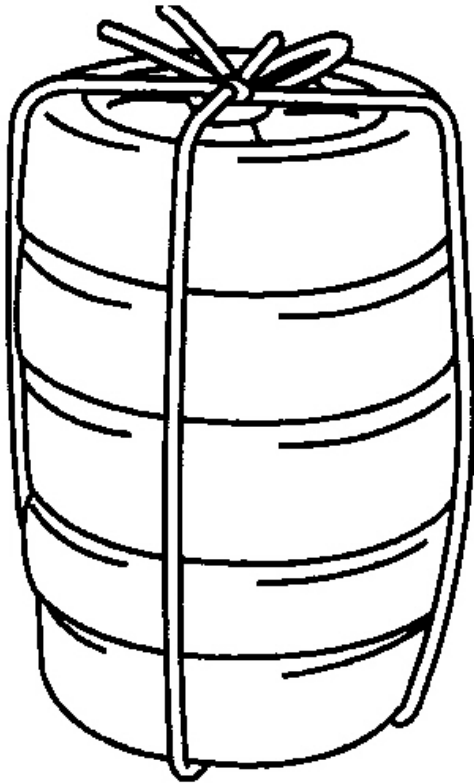

A6E8130W034

**Fig. 57: Tying Tires Together With Wire**  
Courtesy of MAZDA MOTORS CORP.

6. Connect the SSTs (Deployment tool) to the SSTs (Adapter harness).
7. Connect both SSTs (Deployment tool) to the battery. Connect the power supply red clip to the positive battery terminal, and the black clip to the negative battery terminal.
8. Verify that the red lamp on both SSTs (Deployment tool) is illuminated.
9. Verify that all persons are standing **at least 6 m {20 ft}** away from the vehicle.

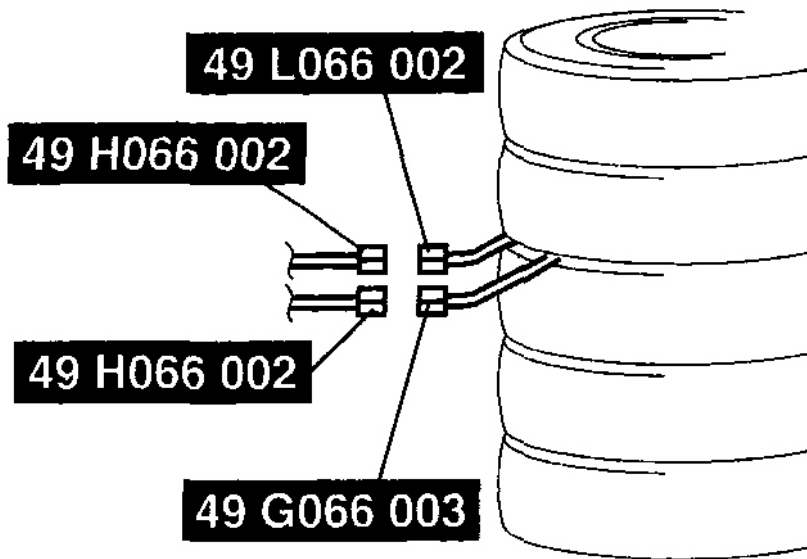

BHJ0810W107

**Fig. 58: Connecting SSTs (Deployment Tool) To SSTs (Adapter Harness)**  
Courtesy of MAZDA MOTORS CORP.

10. Press the activation switch on the **SST** (Deployment tool) connected with 49 L066 002 (a yellow connector) of the **SST** (Adapter harness), and **after 3 s** , press the activation switch on the other **SST** (Deployment tool) to operate (deploy) the air bag module (both inflators).

49 H066 002

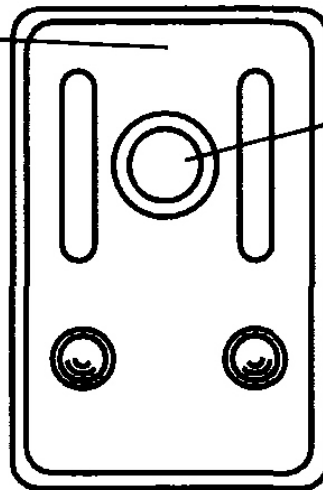

ACTIVATION  
SWITCH

A6E8130W028

**Fig. 59: Identifying Activation Switch**  
Courtesy of MAZDA MOTORS CORP.

**WARNING:**

- Verify that air bag module operation (explosive) sound occurs twice. If no operation (explosive) sound was heard or a single operation (explosive) sound was heard, both inflators would not have operated (deployed) properly. This may cause serious injury if the air bag module operates (deploy) unexpectedly. If the two operation (explosive) sounds are not heard, perform Step 8 again. If a total of two operation (explosive) sounds cannot be verified even though Step 8 is performed again, leave the air bag module alone for 30 min or more before approaching it again.
- The air bag module is very hot immediately after it is operated (deployed). You can be burned. Do not touch the air bag module for at least 15 min after deployment.

11. Disconnect the SSTs (Deployment tool) from the SSTs (Adapter harness).

**SIDE AIR BAG MODULE**

1. Remove the side air bag module. (See **SIDE AIR BAG MODULE REMOVAL/INSTALLATION** .)
2. Install the nuts to the side air bag module as shown in **Fig. 60** , and connect the SST (Adapter harness).

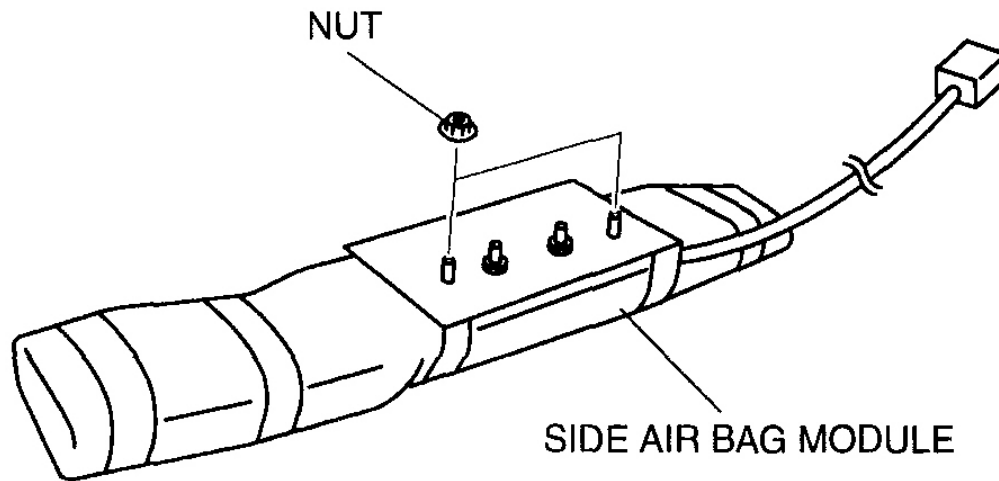

E5U810ZW5031

**Fig. 60: Installing Nuts To Side Air Bag Module & Connect SST (Adapter Harness)**  
Courtesy of MAZDA MOTORS CORP.

3. Place the padded surface of the side air bag module facing the center of the tire as shown in **Fig. 61** . To secure the air bag module to the tire wheel, wrap a wire (cross section  $1.25 \text{ mm}^2$  { $0.002 \text{ in}^2$  } or more ) through the tire and around the bolts **at least 4 times** .

**WARNING:**

- If the air bag module is not properly secured to the tire, the tires may fall over by the impact of operation (deployment) and cause serious injury. To prevent this, secure the air bag module properly with the padded surface facing the center of the tire.

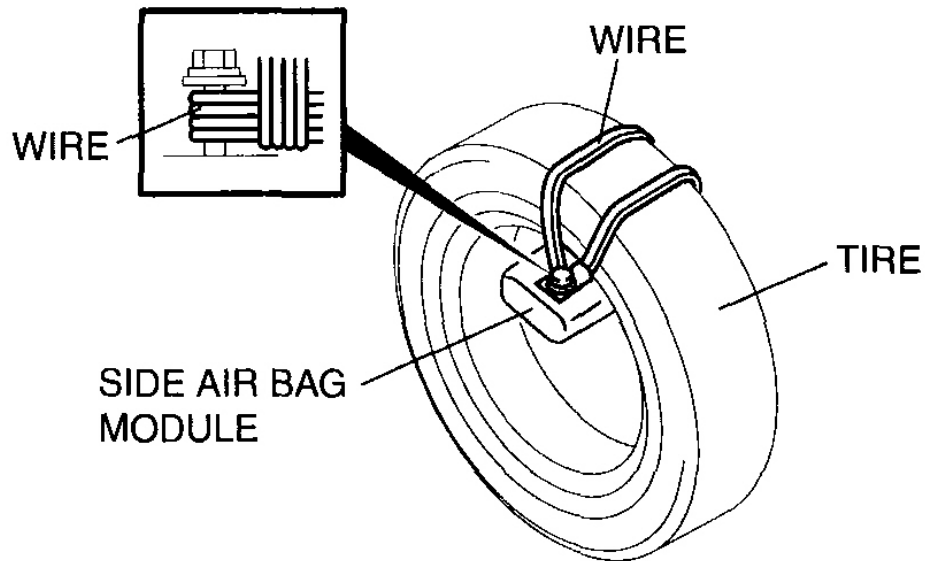

B3E0810W036

**Fig. 61: Placing Padded Surface Of Side Air Bag Module Facing Center Of Tire**  
Courtesy of MAZDA MOTORS CORP.

4. Connect the SST (Adapter harness) to the side air bag module as shown in **Fig. 62** .

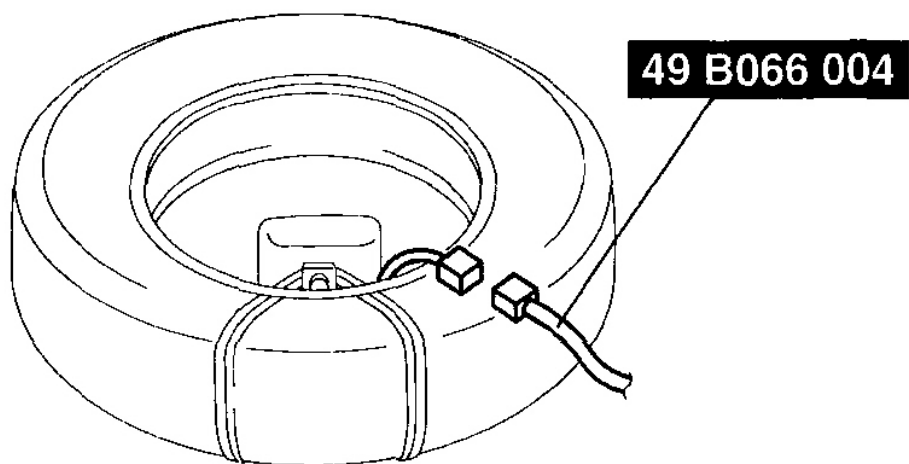

E5U810ZW5138

**Fig. 62: Connecting SST (Adapter Harness) To Side Air Bag Module**  
Courtesy of MAZDA MOTORS CORP.

5. Stack the tire with the side air bag module on top of two tires without wheels. Stack a tire without a wheel on top of the tire with the side air bag module, and then stack another tire with a wheel on the very top.

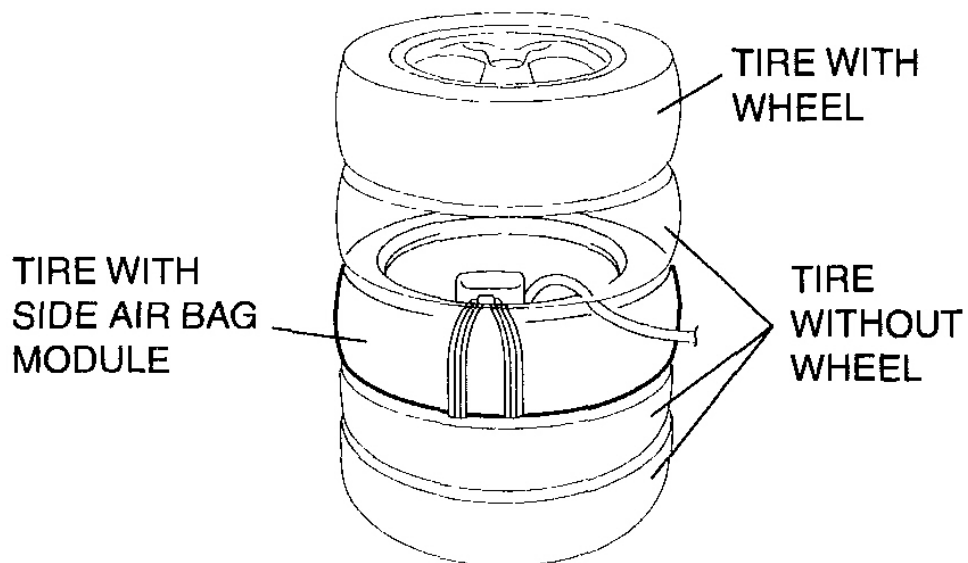

DPE810ZW1037

**Fig. 63: Stacking Tire With Side Air Bag Module On Top Of Tires Without Wheels**  
Courtesy of MAZDA MOTORS CORP.

6. Secure the tires with wire.



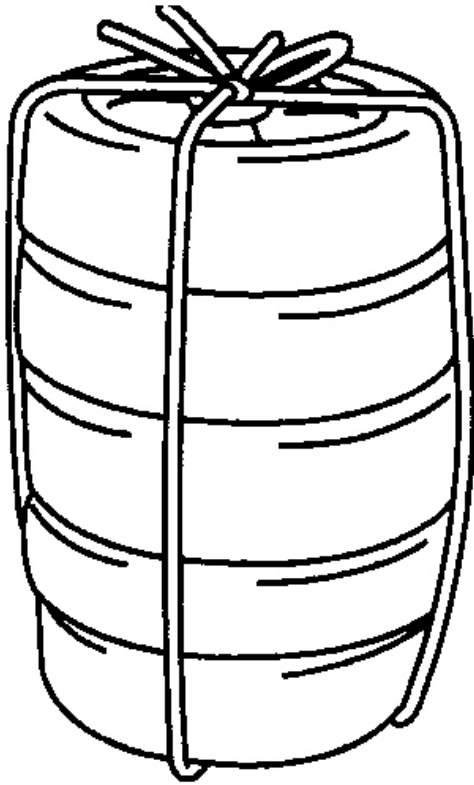

A6E8130W034

**Fig. 64: Tying Tires Together With Wire**  
Courtesy of MAZDA MOTORS CORP.

7. Connect the **SST** (Deployment tool) to the **SST** (Adapter harness).
8. Connect the **SST** (Deployment tool) to the battery. Connect the power supply red clip to the positive battery terminal, and the black clip to the negative battery terminal.
9. Verify that the red lamp on the **SST** (Deployment tool) is illuminated.
10. Verify that all persons are standing **at least 6 m {20 ft}** away from the vehicle.

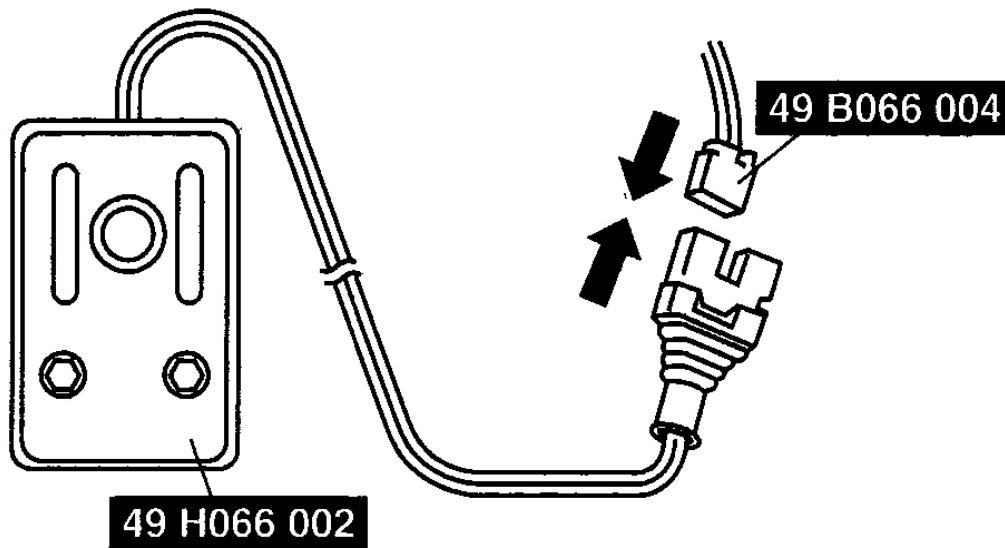

E5U810ZW5139

**Fig. 65: Connecting SST (Deployment Tool) To SST (Adapter Harness)**  
Courtesy of MAZDA MOTORS CORP.

11. Press the activation switch on the SST (Deployment tool) to operate (deploy) the side air bag module.
12. Disconnect the SSTs (Deployment tool) from the SSTs (Adapter harness).

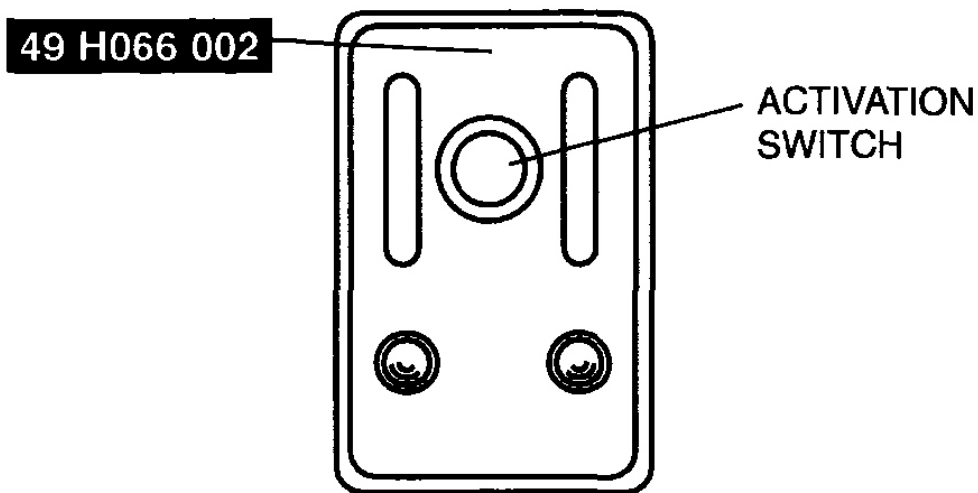

A6E8130W028

**Fig. 66: Identifying Activation Switch**  
Courtesy of MAZDA MOTORS CORP.

### PRE-TENSIONER SEAT BELT

1. Remove the pre-tensioner seat belt. (See **SEAT BELT REMOVAL/INSTALLATION** .)
2. Connect the **SST** (Adapter harness) to the pre-tensioner seat belt as shown in **Fig. 67** .

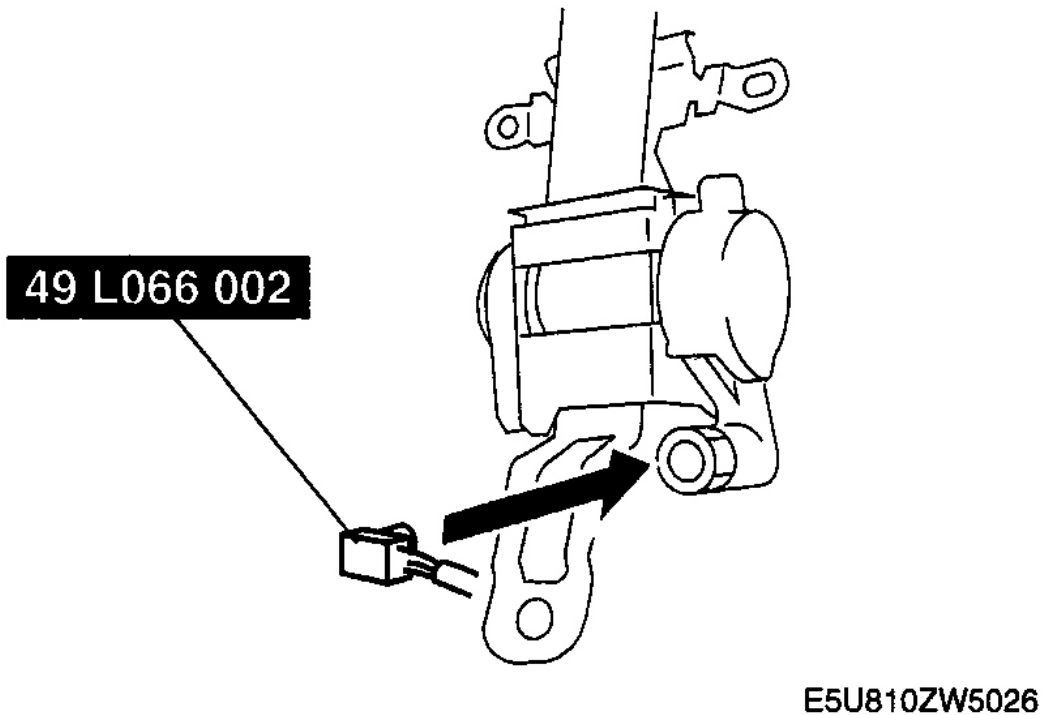
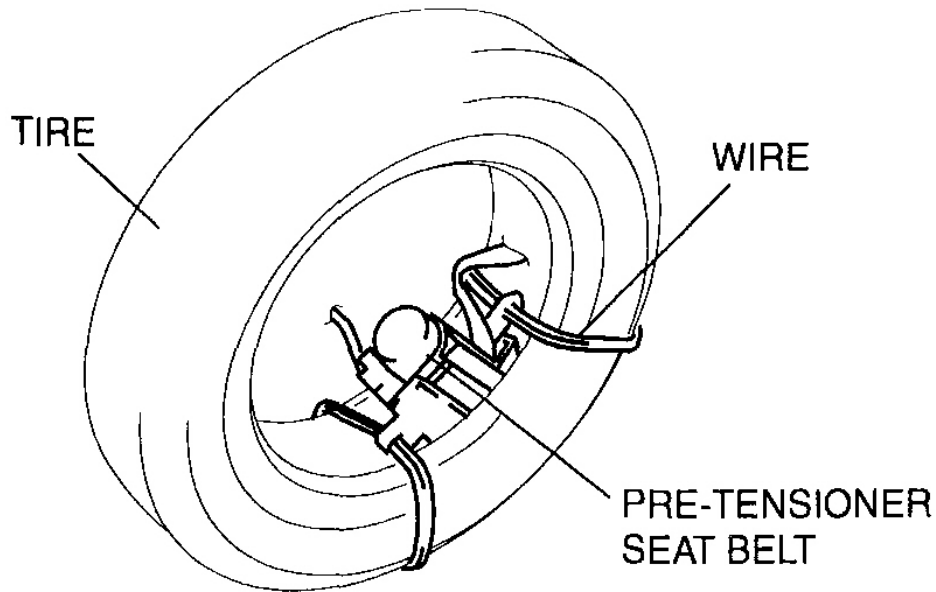

**Fig. 67: Connecting SST (Adapter Harness) To Pre-Tensioner Seat Belt**  
Courtesy of MAZDA MOTORS CORP.

3. Put the pre-tensioner seat belt inside the tire and secure it to the tire by wrapping a wire (cross section of  $1.25 \text{ mm}^2$  {  $0.002 \text{ in}^2$  } or more ) through the tire and the bolt installation holes **at least 4 times** .

**WARNING:**

- If the pre-tensioner seat belt is not properly installed to the tire, serious injury may occur when the pre-tensioner part is operated (deployed). When installing the pre-tensioner seat belt to the tire, make sure the pre-tensioner part is inside the tire.



DPE810ZW1033

**Fig. 68: Putting Pre-Tensioner Seat Belt Inside Tire & Secure To Tire By Wrapping Wire**  
Courtesy of MAZDA MOTORS CORP.

4. Stack the tire with the pre-tensioner seat belt on two of tires without wheels. Stack a tire without a wheel on top of the tire with the pre-tensioner seat belt, and then stack another tire with a wheel on the very top.

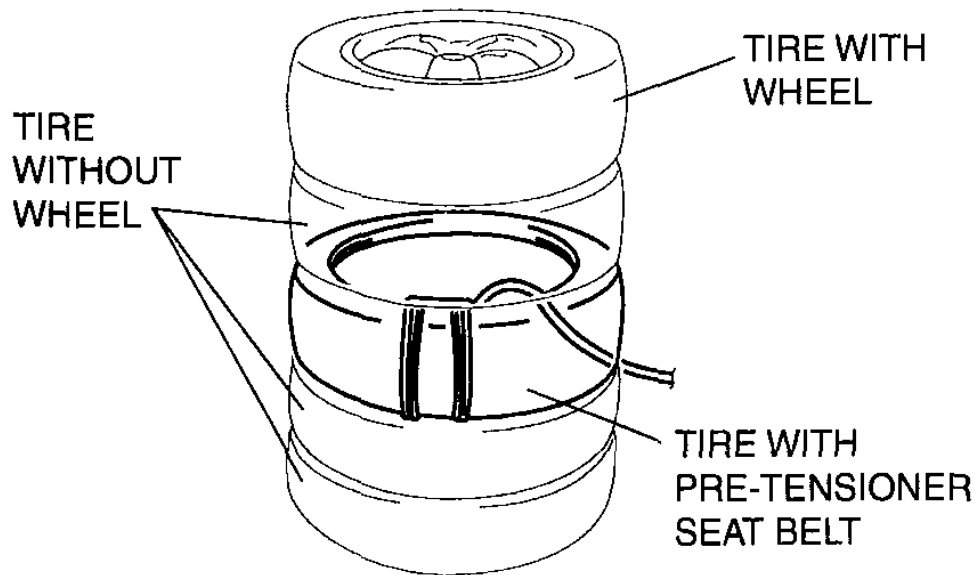

DPE810ZW1034

**Fig. 69: Stacking Tire With Pre-Tensioner Seat Belt On Two Of Tires Without Wheels**  
Courtesy of MAZDA MOTORS CORP.

5. Secure the tires with wire.

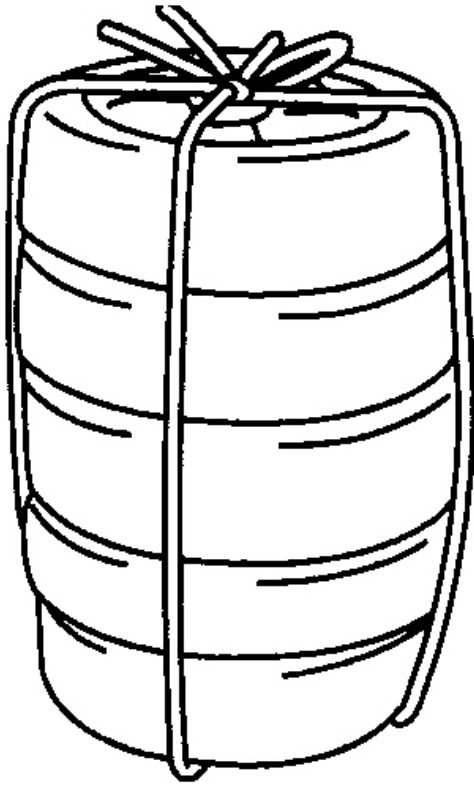

A6E8130W034

**Fig. 70: Tying Tires Together With Wire**  
Courtesy of MAZDA MOTORS CORP.

6. Connect the **SST** (Deployment tool) to the **SST** (Adapter harness).
7. Connect the **SST** (Deployment tool) to the battery. Connect the power supply red clip to the positive battery terminal, and the black clip to the negative battery terminal.
8. Verify that the red lamp on the **SST** (Deployment tool) is illuminated.
9. Verify that all persons are standing **at least 6 m {20 ft}** away from the vehicle.

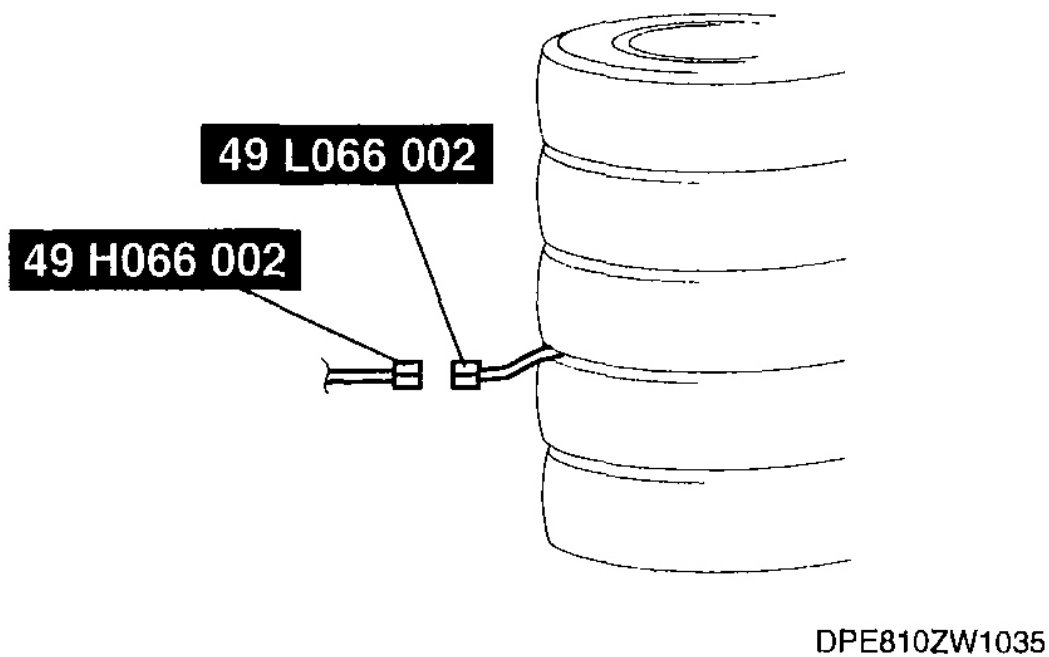
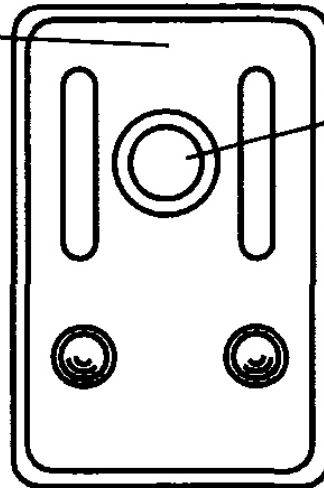

**Fig. 71: Connecting SST (Deployment Tool) To SST (Adapter Harness)**  
Courtesy of MAZDA MOTORS CORP.

10. Press the activation switch on the **SST** (Deployment tool) to operate (deploy) the pre-tensioner seat belt.
11. Disconnect the **SSTs** (Deployment tool) from the **SSTs** (Adapter harness).



49 H066 002



ACTIVATION  
SWITCH

A6E8130W028

**Fig. 72: Identifying Activation Switch**  
Courtesy of MAZDA MOTORS CORP.

## AIR BAG MODULE AND PRE-TENSIONER SEAT BELT DISPOSAL PROCEDURES

### WARNING:

- A live (undeployed) air bag module or pre-tensioner seat belt may accidentally operate (deploy) when it is disposed of and cause serious injury. Always refer to the AIR BAG MODULE AND PRE-TENSIONER SEAT BELT DEPLOYMENT PROCEDURES and dispose of air bag modules and pre-tensioner seat belts in a deployed condition.
- The air bag modules and the pre-tensioner seat belts are very hot immediately after they are deployed. You can be burned. Do not touch an air bag module and pre-tensioner seat belt for at least 15 min after deployment.
- Pouring water on the deployed air bag module and pre-tensioner seat belt is dangerous. The water will mix with the residual gases to form a gas that can make breathing difficult. Do not pour water on the deployed air bag module and pre-tensioner seat belt.
- The deployed air bag module or pre-tensioner seat belt may contain deposits of sodium hydroxide, a caustic byproduct of the gas-generated combustion. If this substance gets into your eyes or on your hands, it can cause irritation and itching. When handling the

deployed air bag module and pre-tensioner seat belt, wear gloves and safety glasses.

- Due to the adoption of 2-step deployment control in both the driver and passenger-side air bag modules, depending on the impact force, it is possible that inflator No. 2 might not operate (deploy). Before disposing of the air bag module, always follow the inflator deployment procedures and verify the complete operation (deployment) of inflators No. 1 and 2.

1. Remove the deployed air bag module or pre-tensioner seat belt.
2. Put the air bag module or pre-tensioner seat belt in a plastic bag, seal the bag, and then dispose of it.

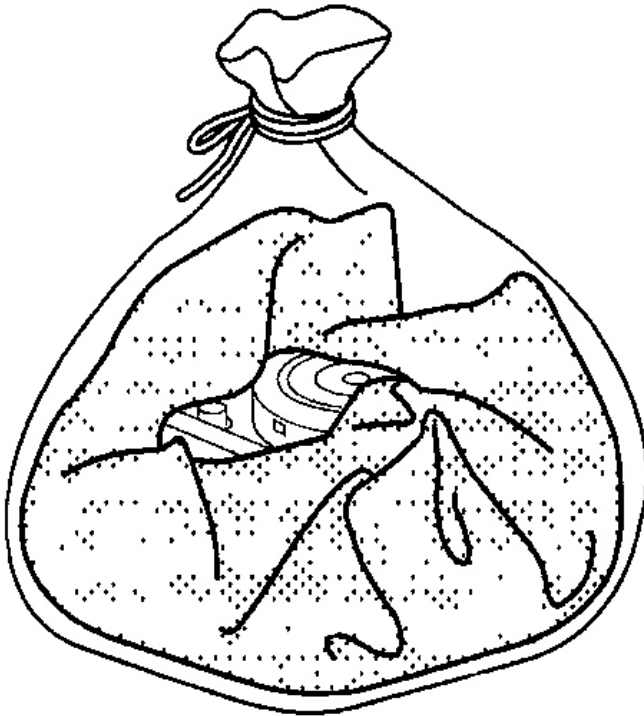

BHJ0810W023

**Fig. 73: Putting Air Bag Module Or Pre-Tensioner Seat Belt In Plastic Bag**  
Courtesy of MAZDA MOTORS CORP.

## **INSPECTION OF SST (DEPLOYMENT TOOL)**

1. Before using the SST (49 H066 002), inspect its operation.

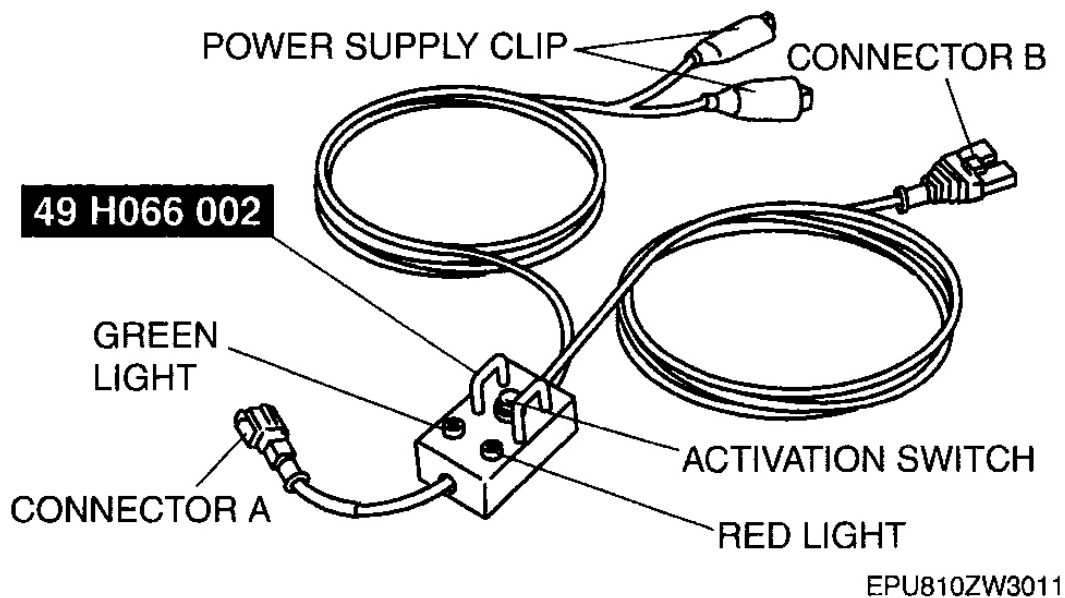

**Fig. 74: Inspecting SST (Deployment Tool)**  
 Courtesy of MAZDA MOTORS CORP.

**INSPECTION PROCEDURE**

1. Follow the steps below to inspect the SST (49 H066 002).
  - If not as indicated in **SST INSPECTION REFERENCE TABLE** , replace the SST (49 H066 002) because it has a malfunction.

**WARNING:**

- Do not use a malfunctioning SST (49 H066 002), otherwise it could cause the air bag module or pre-tensioner seat belt to accidentally operate (deploy).

**CAUTION:**

- Because the permissible voltage for the SST (49 H066 002) is 12 V, do not connect a 24 V power source because it will damage the SST. Always connect only a 12 V power source.

**SST INSPECTION REFERENCE TABLE**

Step	Inspection procedure	Light condition	
		Green	Red
1	Connect the power supply red clip to the positive battery terminal, and the black clip to the negative battery terminal.	On	Off
2	Connect connectors A and B.	Off	On

3 Press the activation switch.

On Off

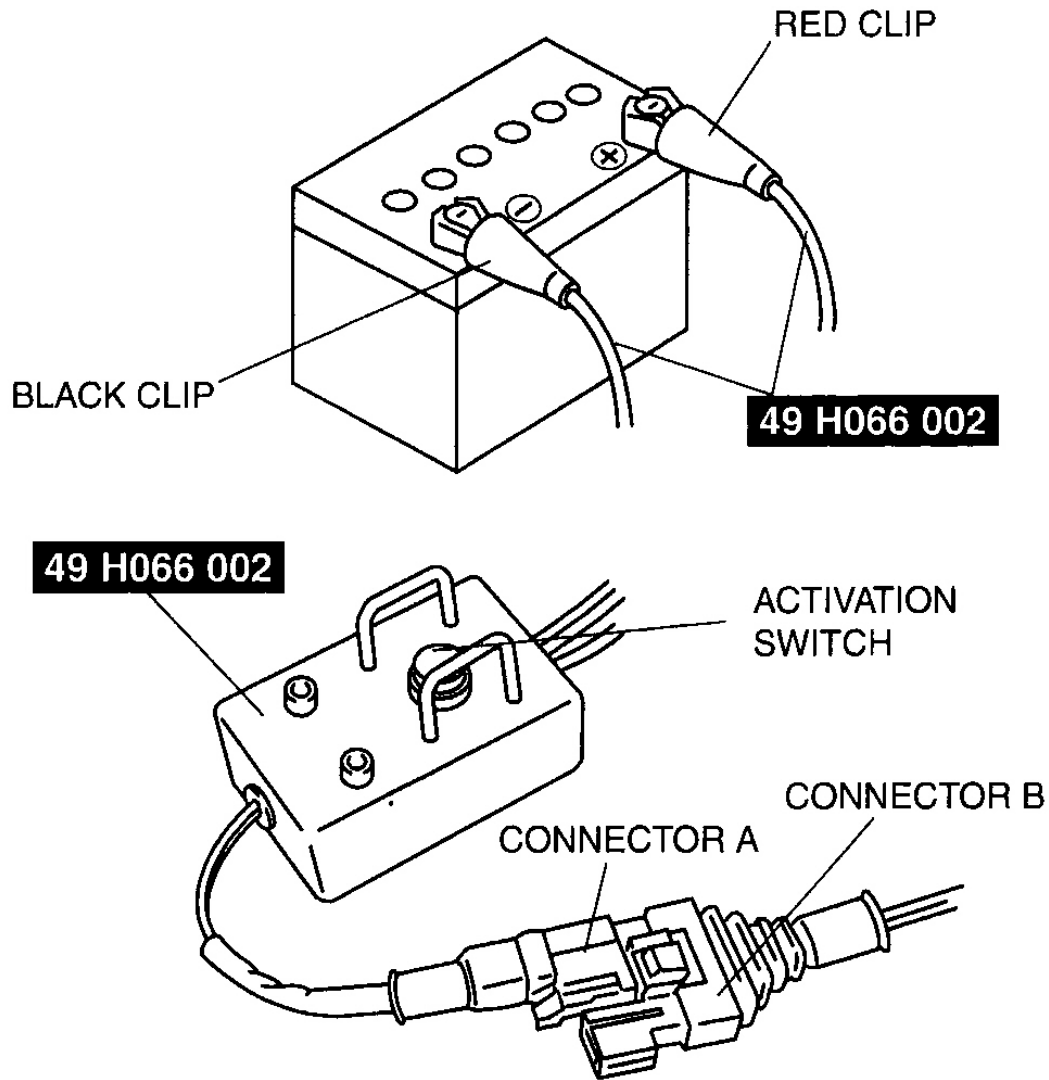

E5U810ZW5050

**Fig. 75: Inspecting Activation Switch**  
Courtesy of MAZDA MOTORS CORP.